

BACK TO SCHOOL

Name: _____

©www.thecurriculumcorner.com

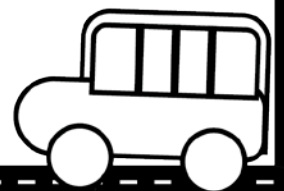

Name: _____

Follow the path.

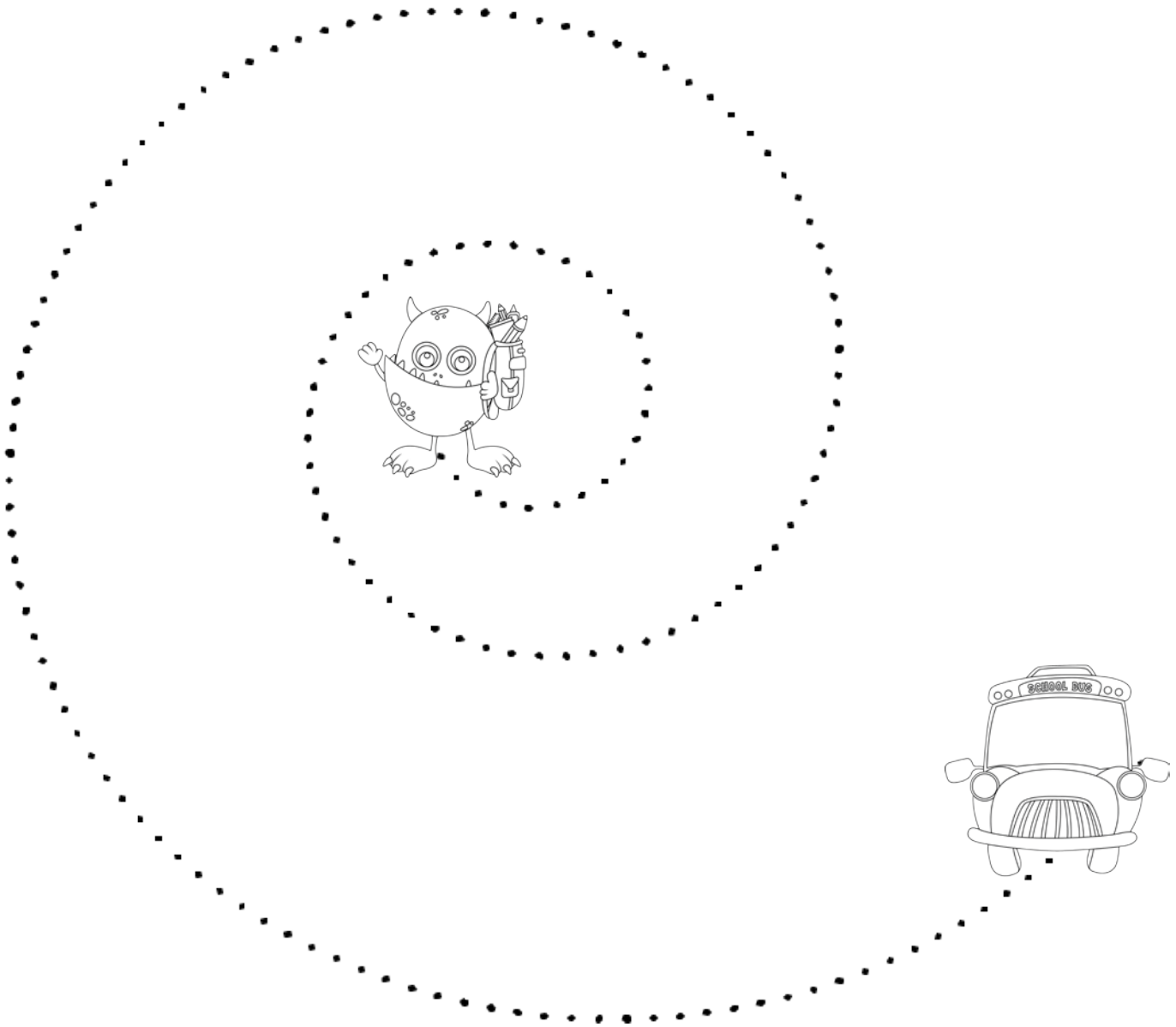

Name: _____

Trace the lines.



Name: _____

Trace the lines.



Name: _____

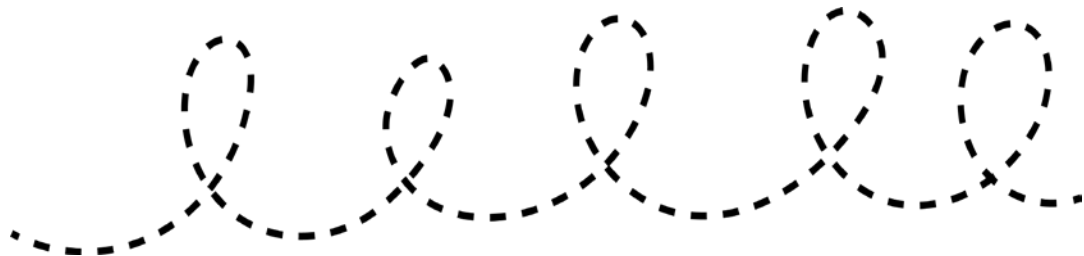
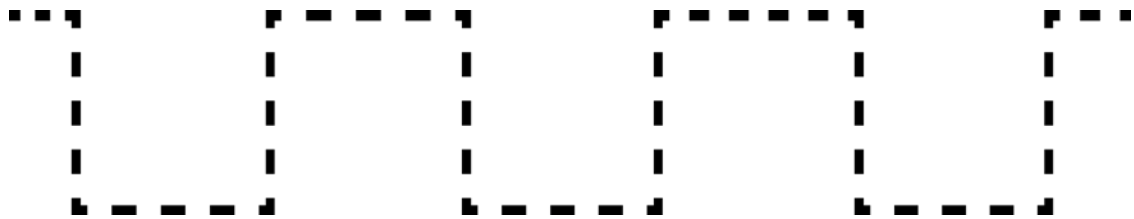

Name: _____

Follow the letter a.

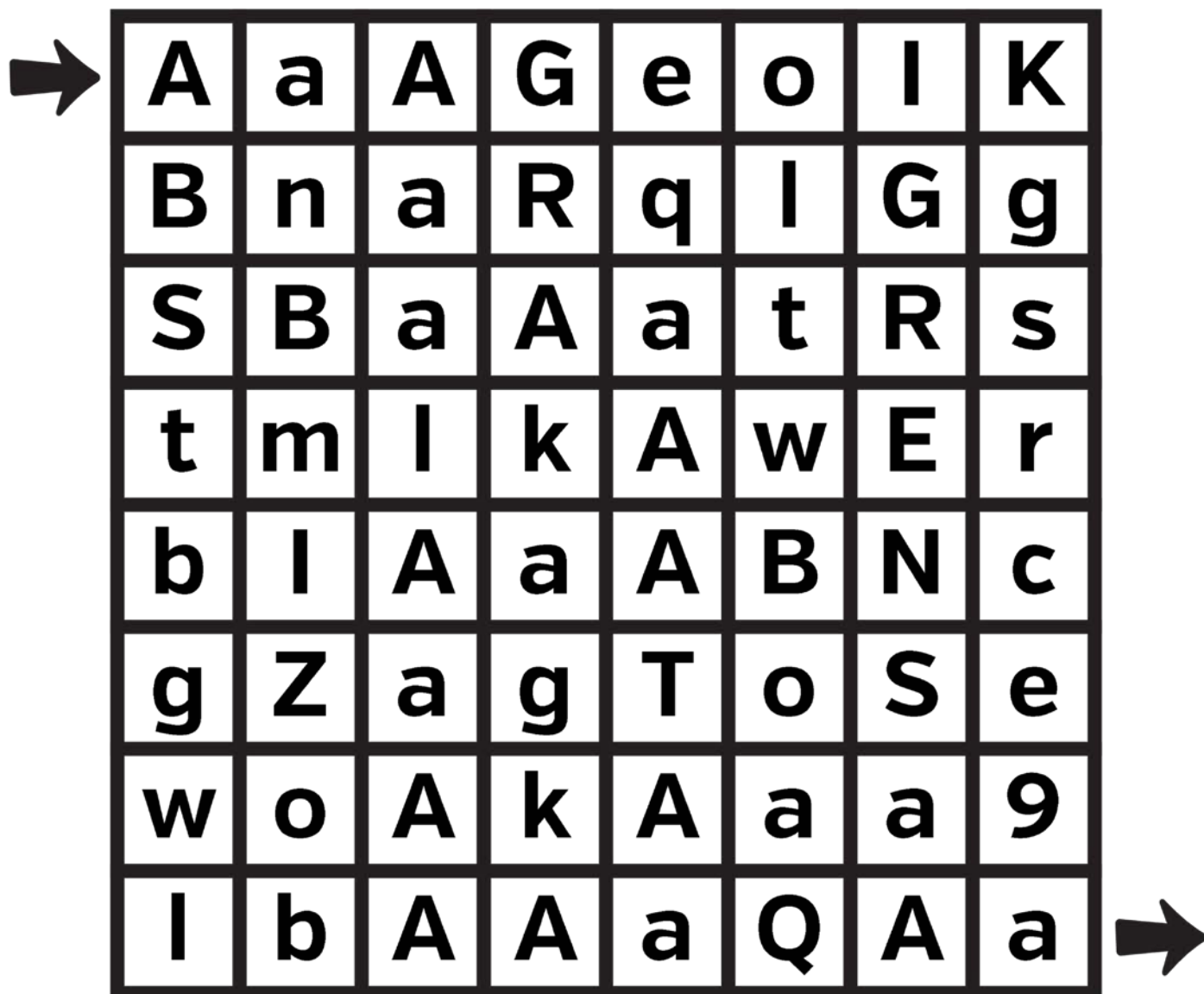

A	a	A	G	e	o	I	K
B	n	a	R	q	I	G	g
S	B	a	A	a	t	R	s
t	m	I	k	A	w	E	r
b	I	A	a	A	B	N	c
g	Z	a	g	T	o	S	e
w	o	A	k	A	a	a	9
I	b	A	A	a	Q	A	a

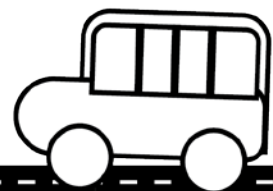

Name: _____

Follow the letter b.

b	B	X	Z	a	F	D	S
t	b	B	B	b	b	B	l
n	B	D	B	b	t	b	O
b	b	l	B	7	w	B	b
b	l	i	b	D	B	N	b
b	Z	a	B	T	B	b	B
B	B	b	b	b	B	S	K
w	o	p	p	S	b	B	b



Name: _____

Follow the letter c.

c	c	C	C	T	o	S	e
E	a	A	c	c	C	c	W
w	g	4	G	b	t	C	s
c	c	C	k	C	c	c	r
C	I	C	I	C	G	N	T
C	Z	c	c	C	o	S	S
c	p	E	n	r	h	S	G
C	C	C	C	c	C	c	c

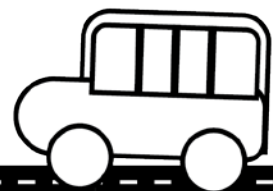

Name: _____

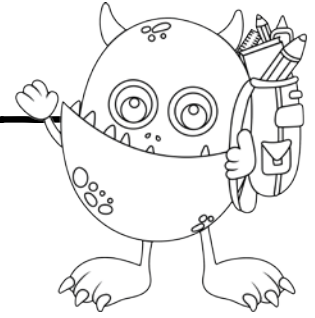

Trace the shapes.

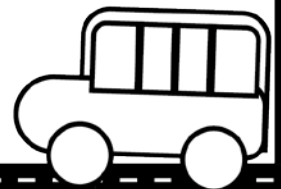
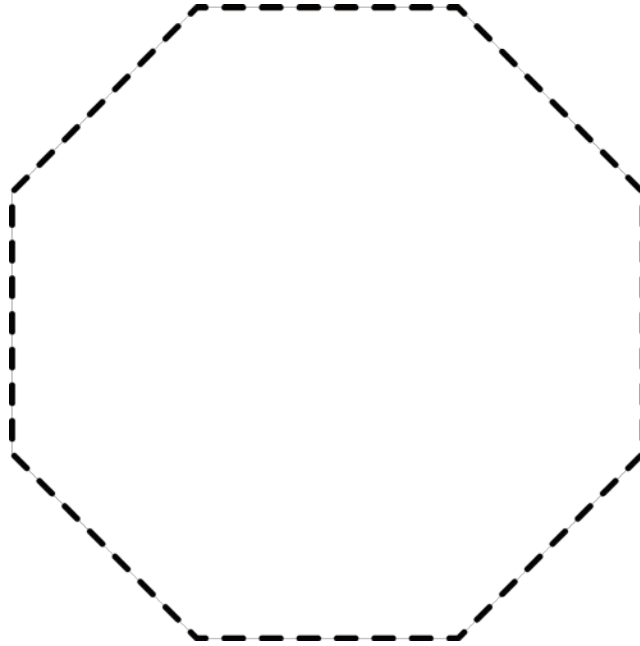

Name: _____

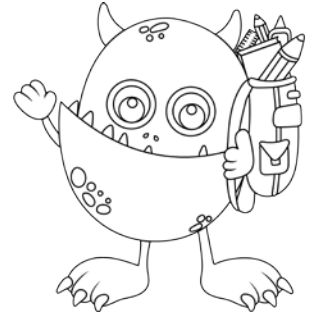

Trace the shapes.

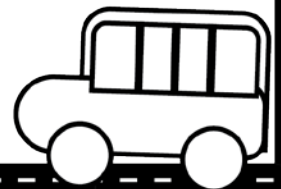
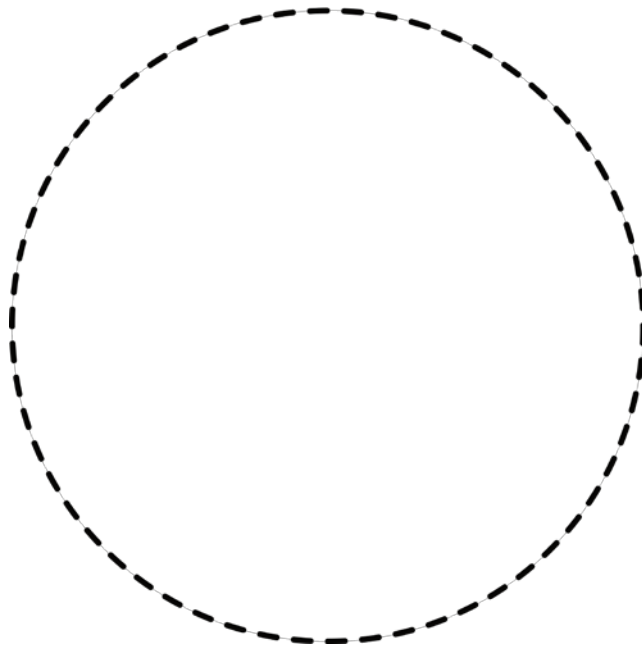
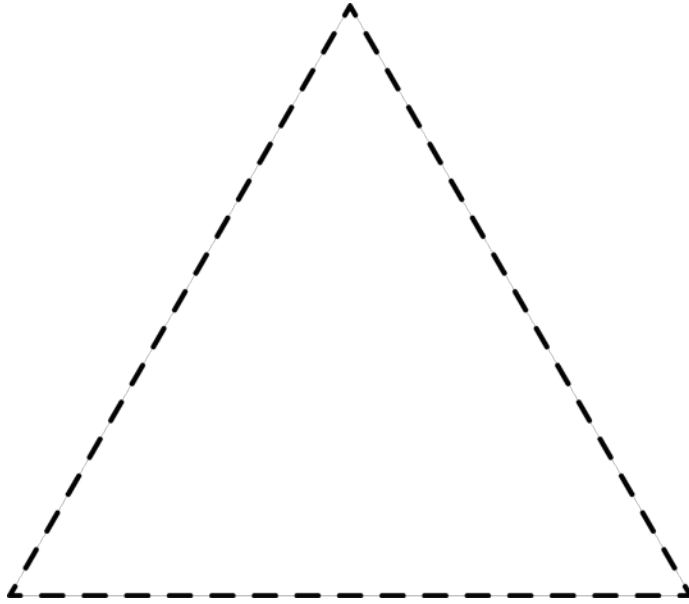

Name: _____

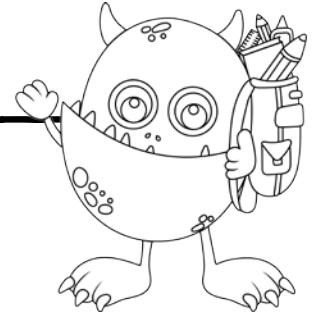

Trace the shapes.

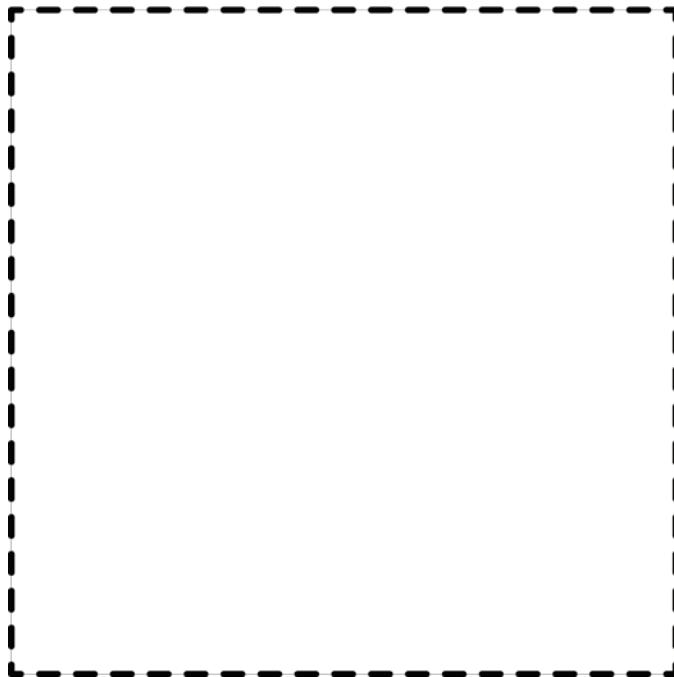
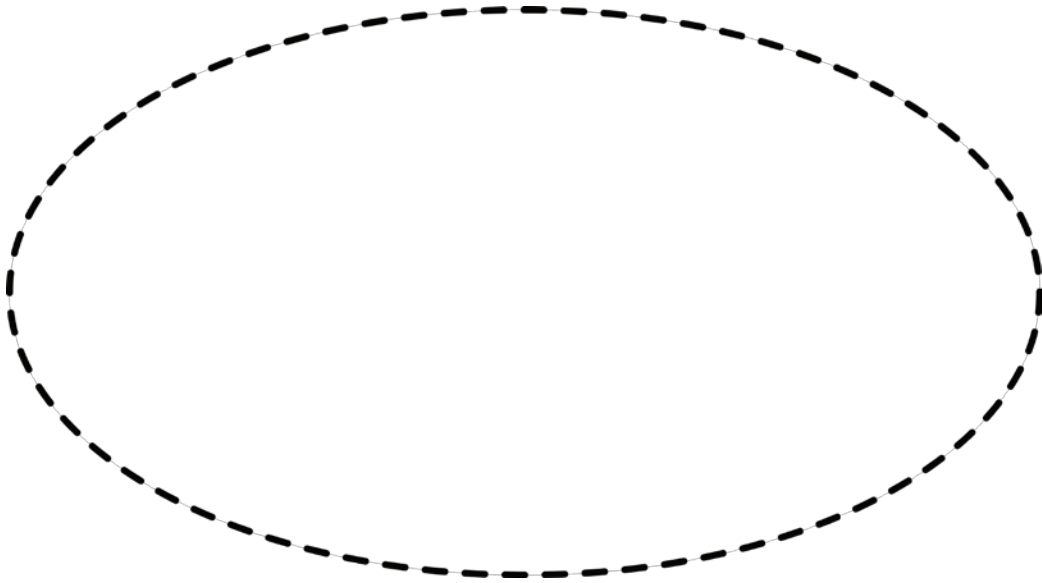

Name: _____

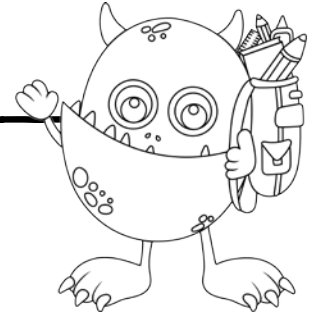

Cut the shapes.

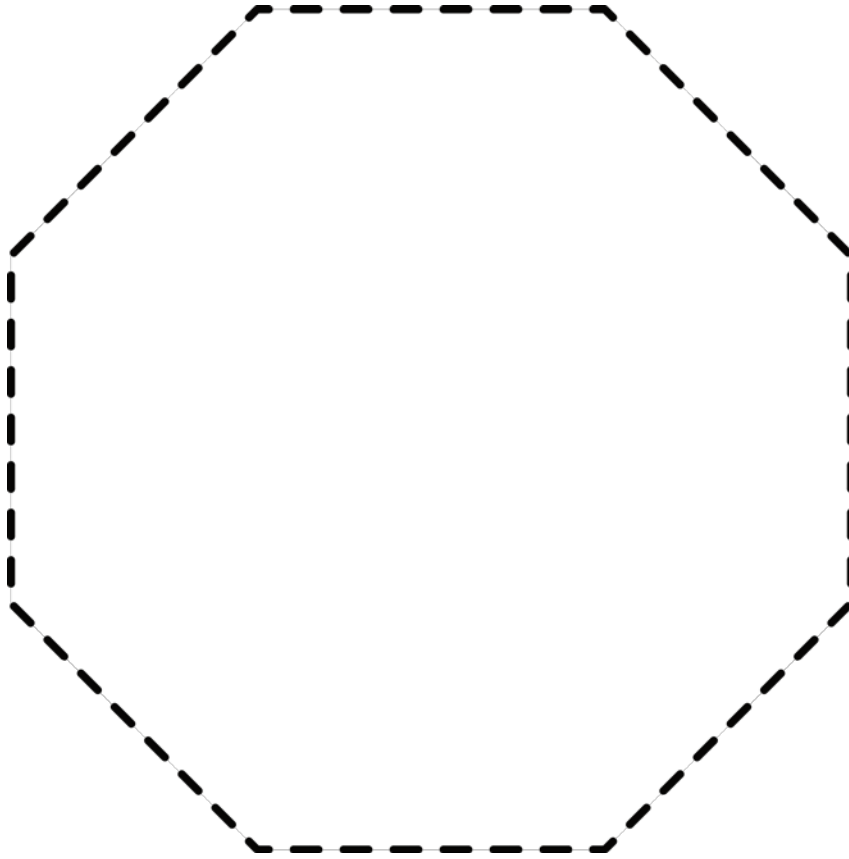

Name: _____

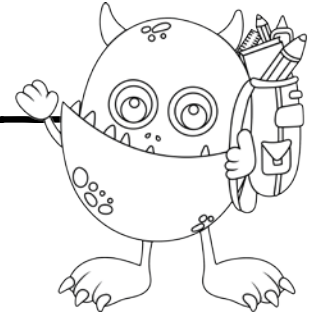

Cut the shapes.

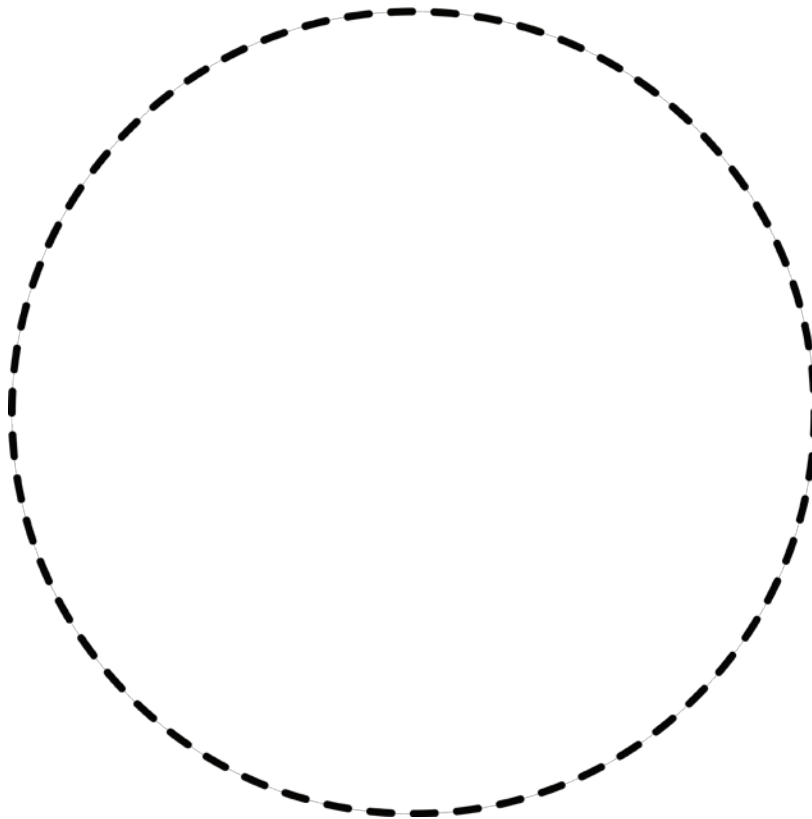
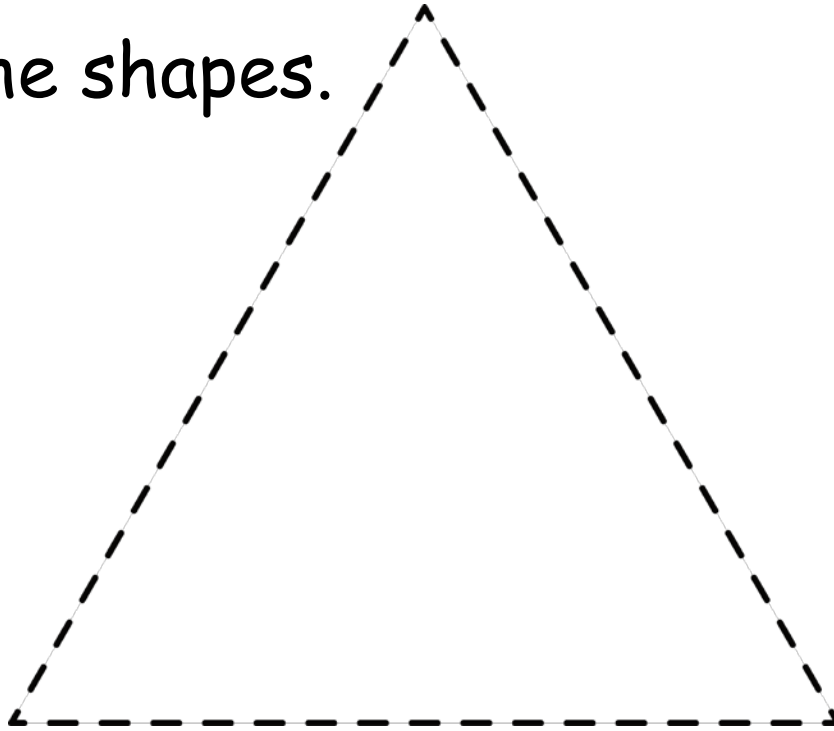

Name: _____

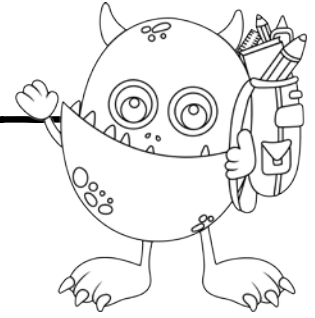

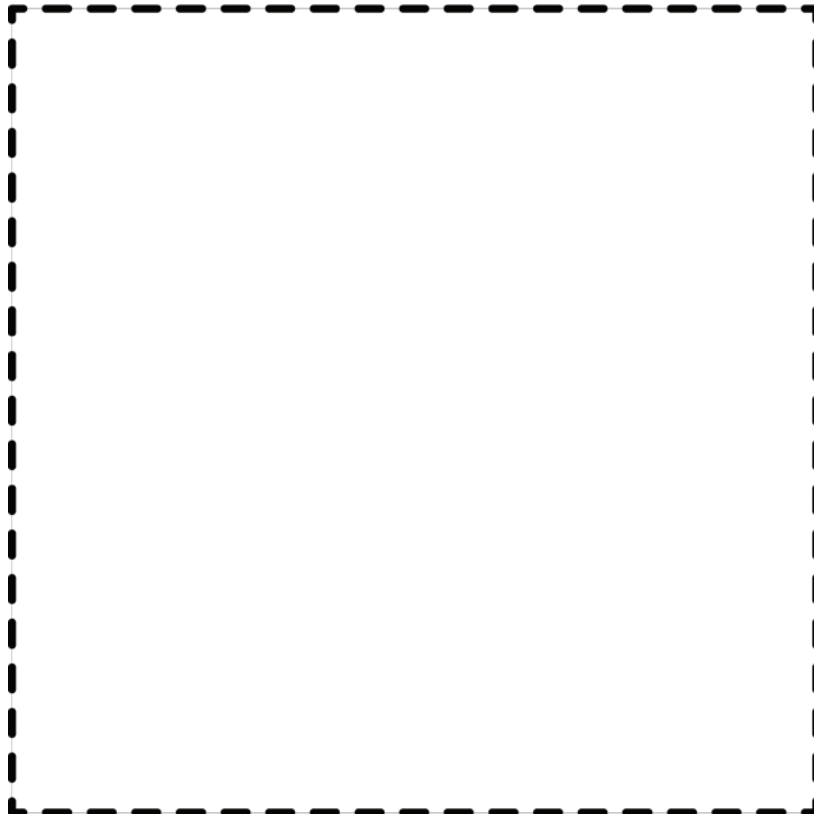
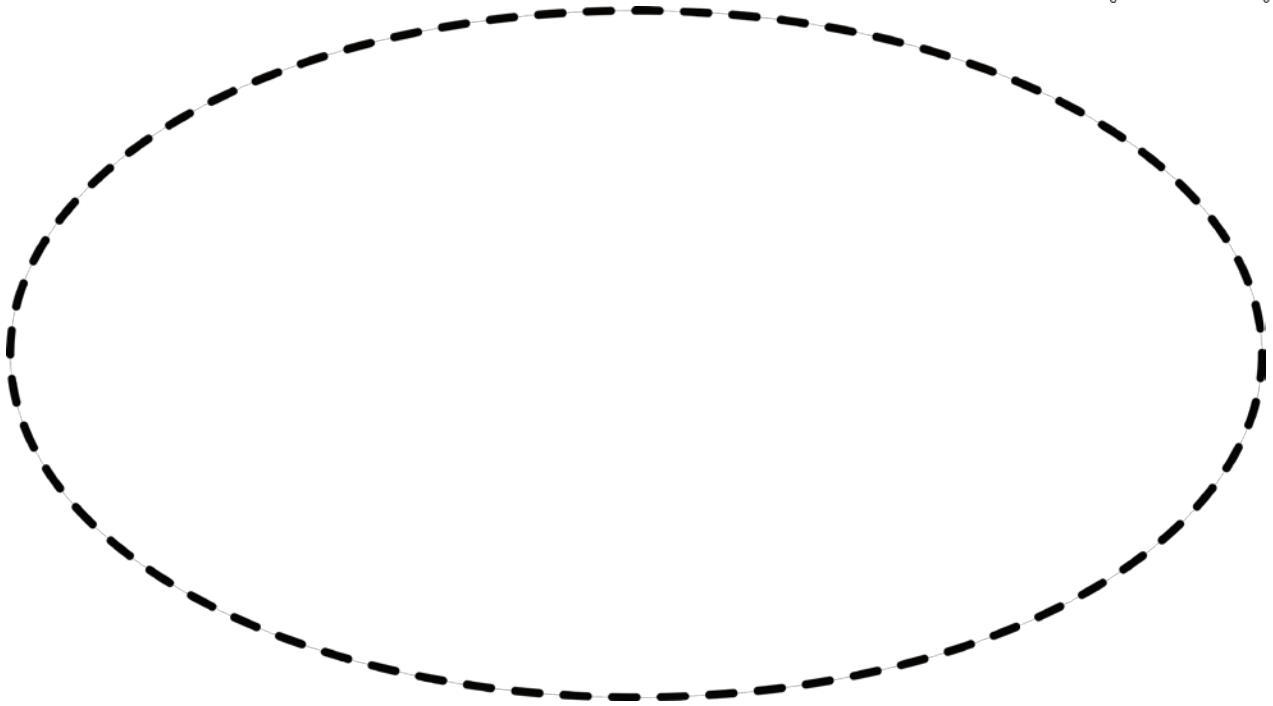

Cut the shapes.

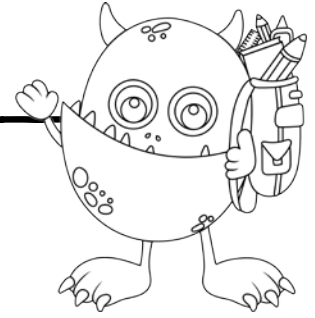

Name: _____

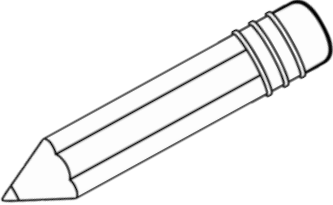

Count the pencils.

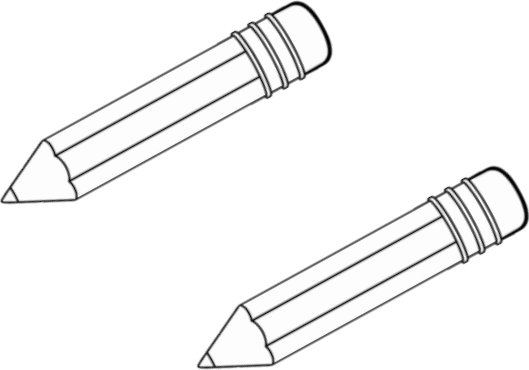
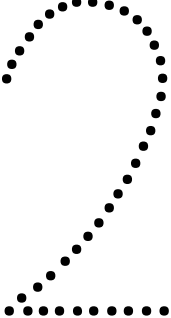
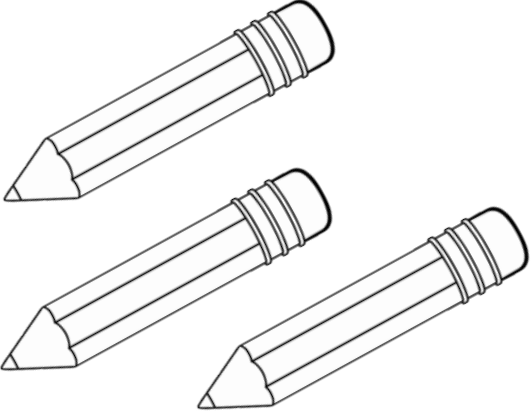
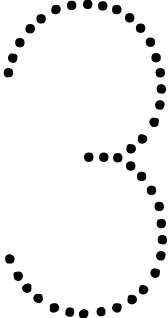



Name: _____

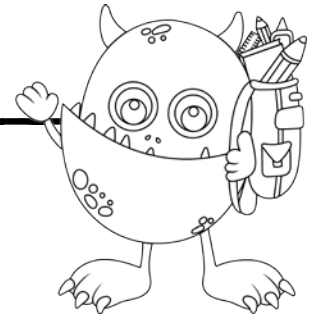

Count the pencils.

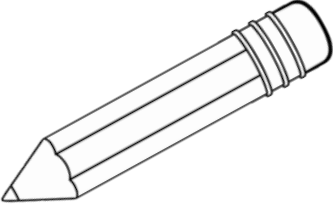
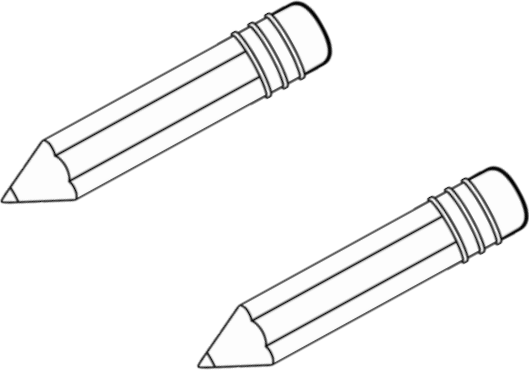
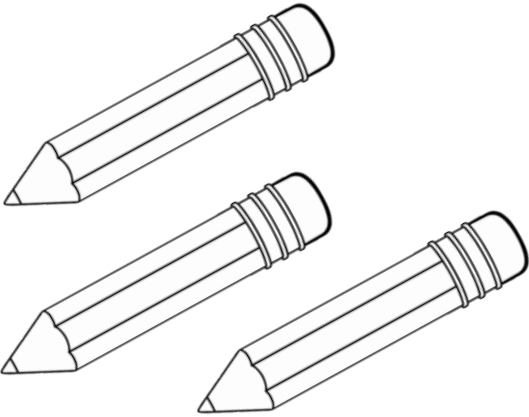



Name: _____

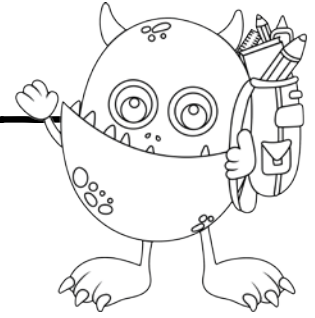

Count the pencils.

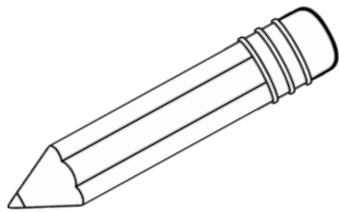

one

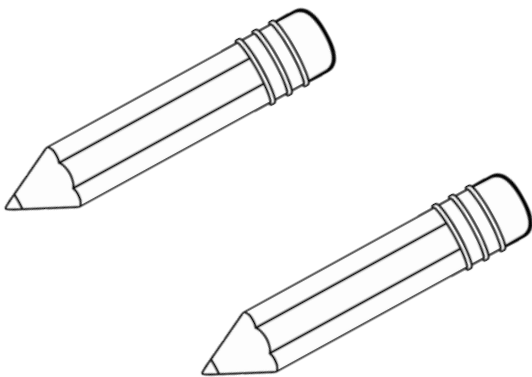

two

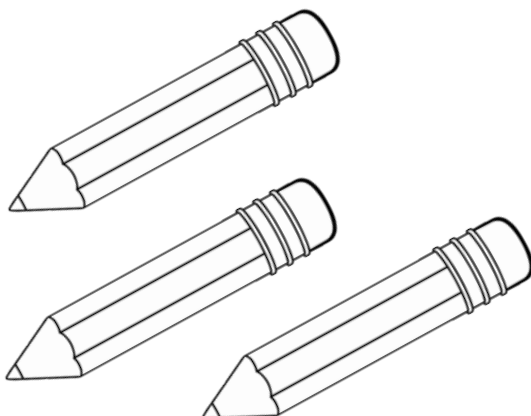

three



Name: _____

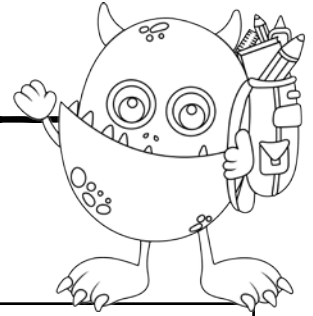

Count the crayons.

A single crayon with the word "Crayon" written on its label.	1
Two crayons, one above the other, both with the word "Crayon" on their labels.	2
Three crayons arranged in a fan shape, each with the word "Crayon" on its label.	3
Four crayons arranged in a fan shape, each with the word "Crayon" on its label.	4



Name: _____

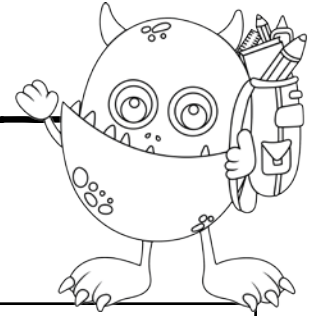

Count the crayons.

A single crayon with the word "Crayon" written on its side.	
Two crayons, one above the other, both with the word "Crayon" written on their sides.	
Three crayons arranged in a fan shape, each with the word "Crayon" written on its side.	
Four crayons arranged in a fan shape, each with the word "Crayon" written on its side.	



Name: _____

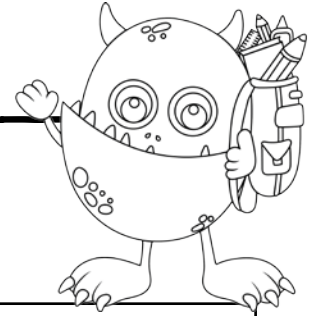

Count the crayons.

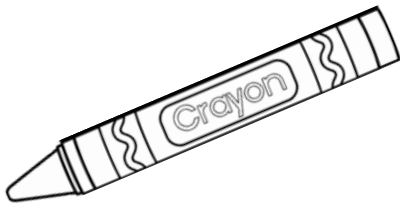

one

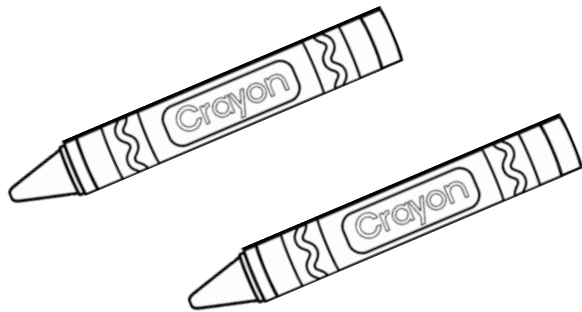

two

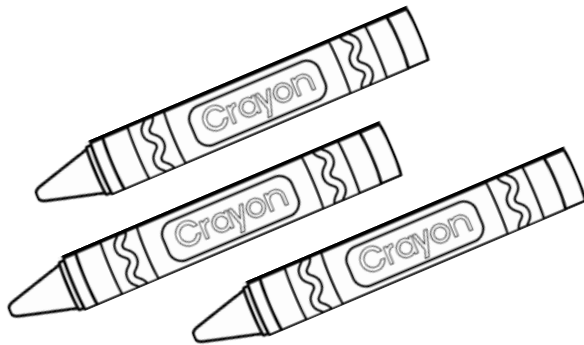

three

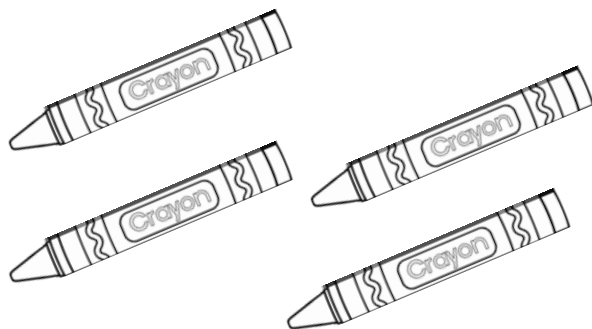





four

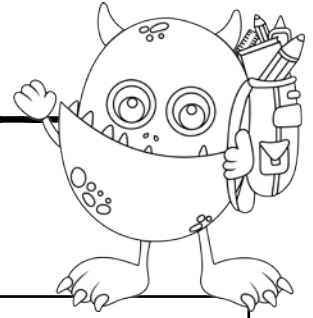

Name: _____

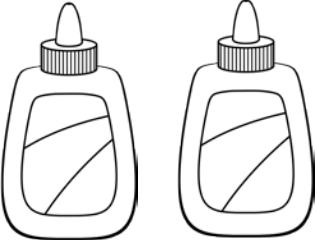

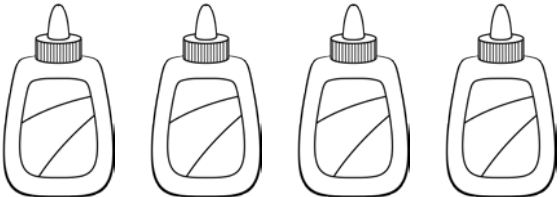
Count the glue.





	1
	2
	3
	4
	5

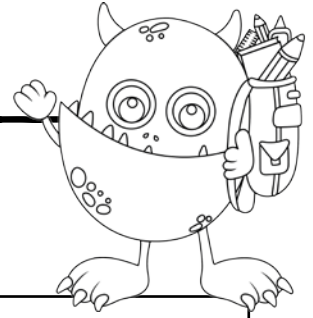

Name: _____

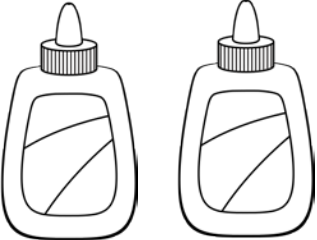

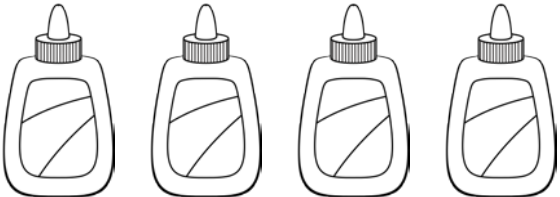
Count the glue.



Name: _____

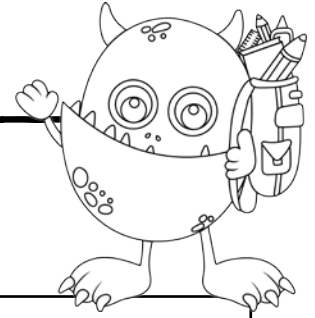

Count the glue.



one

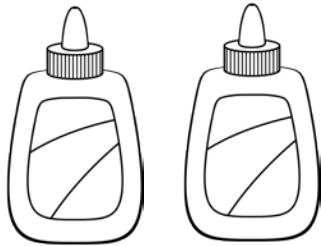

two



three

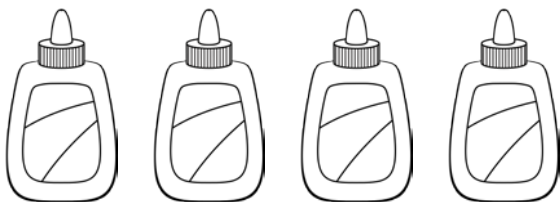

four

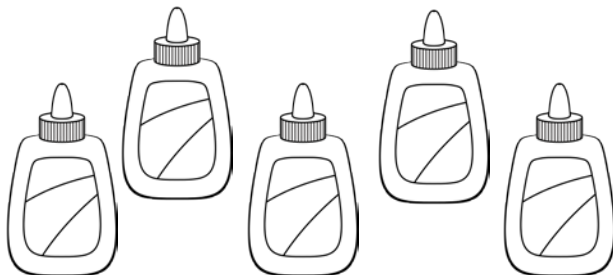

five



Name: _____

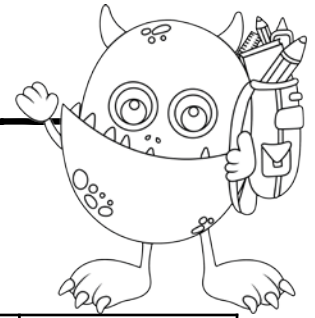

Color the number.

4

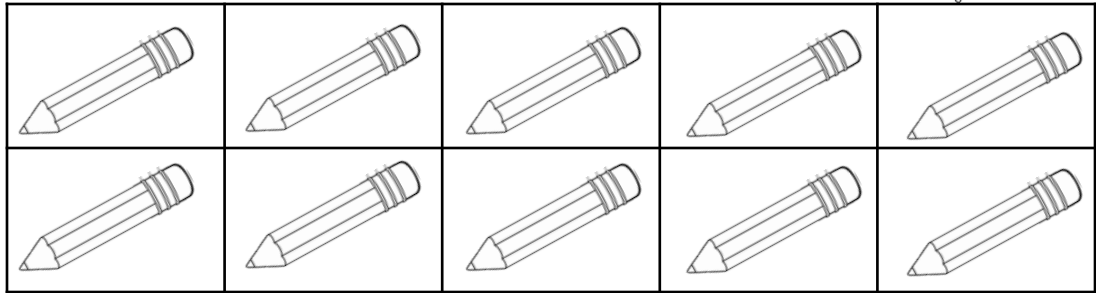

1

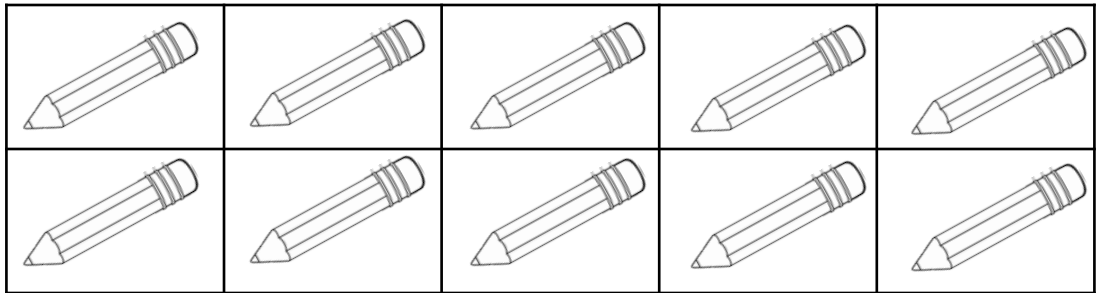

7

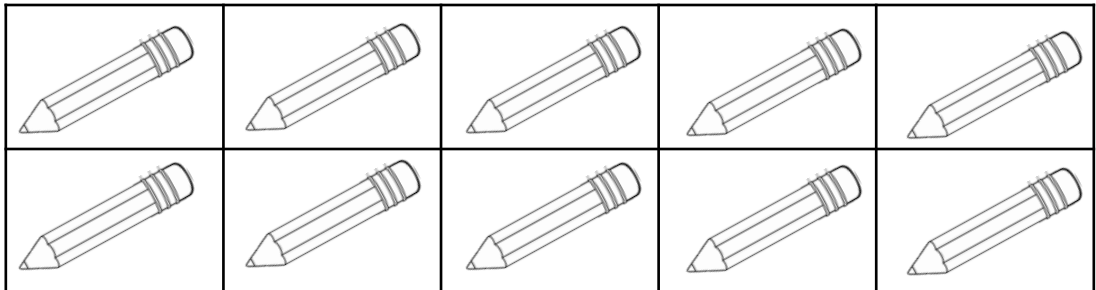

10

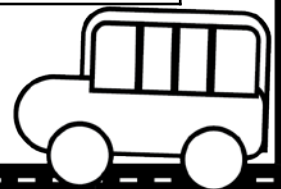
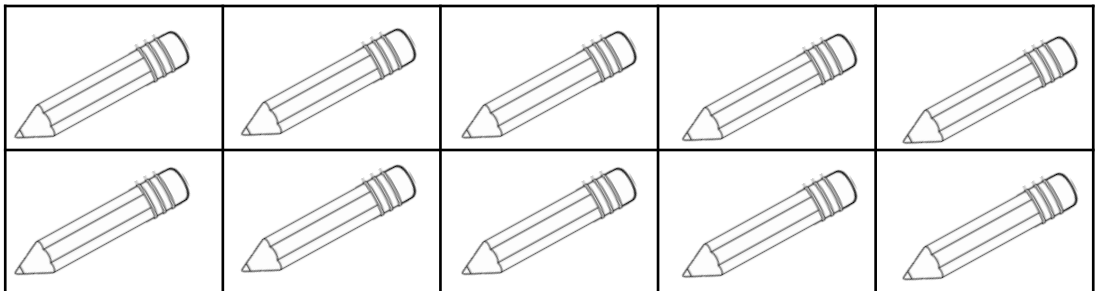

Name: _____

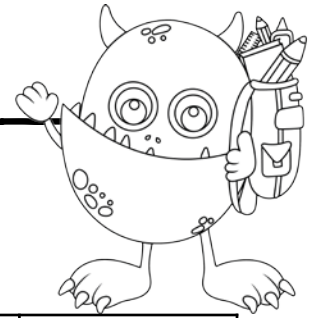

Color the number.

6

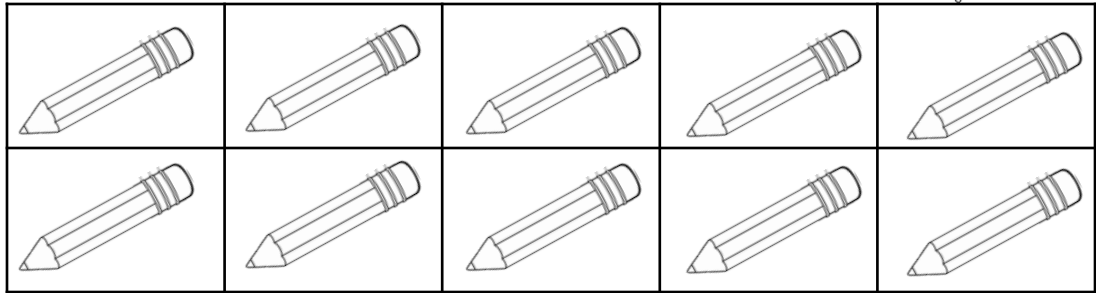

8

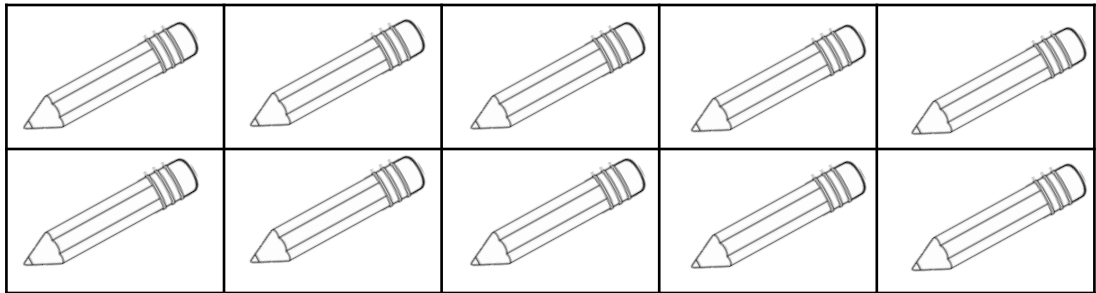

3

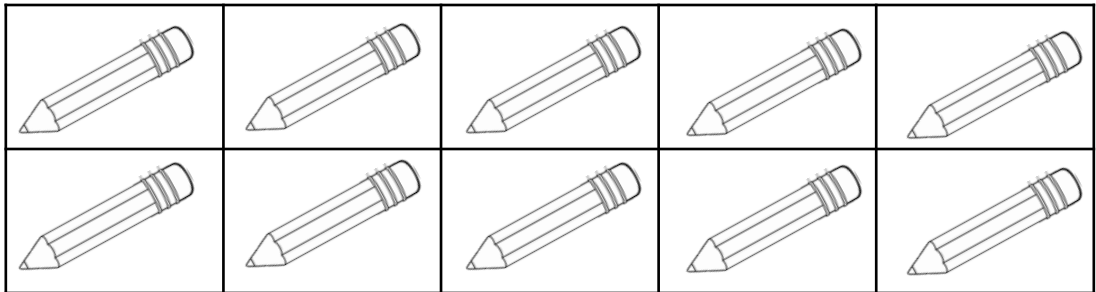

5

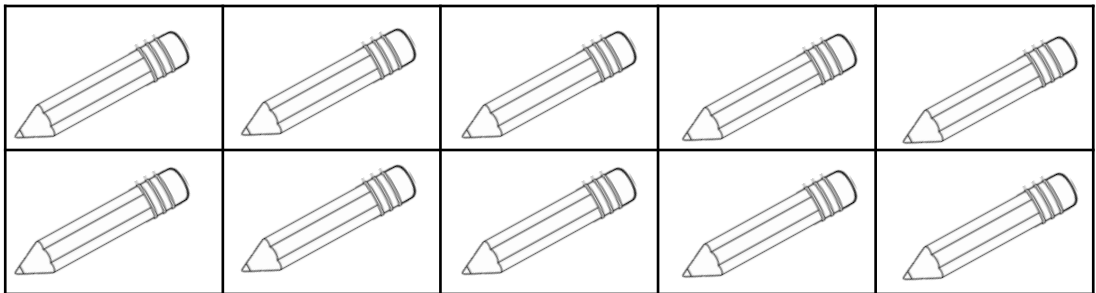

Name: _____

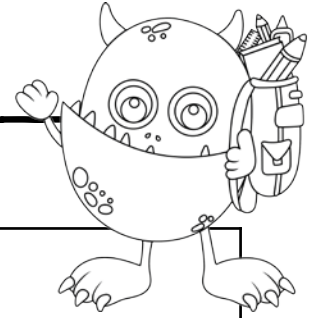

school

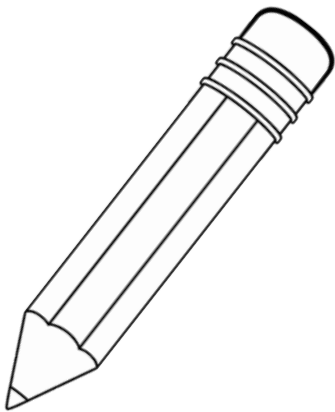

pencil

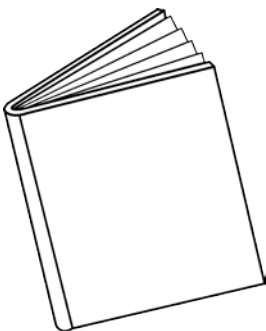

book

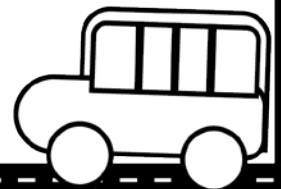

Name: _____

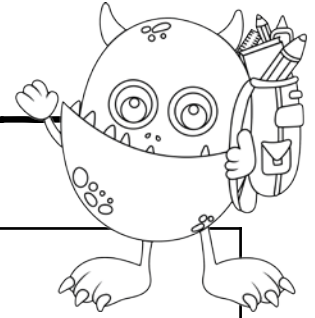

crayon

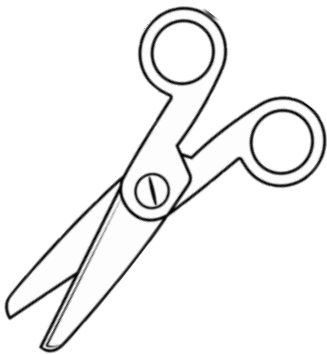

scissors



glue



Name: _____

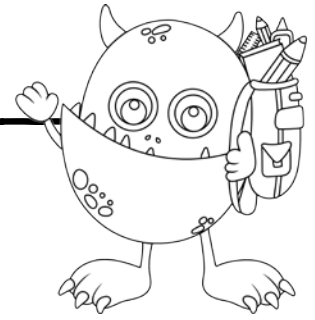

Match the pictures.

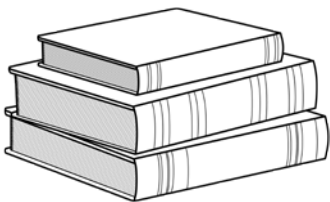
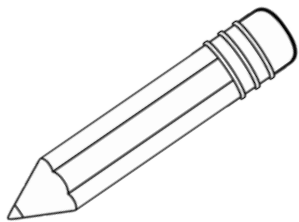

Name: _____

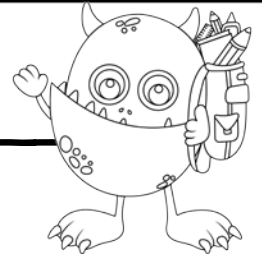

Color the picture that is different.

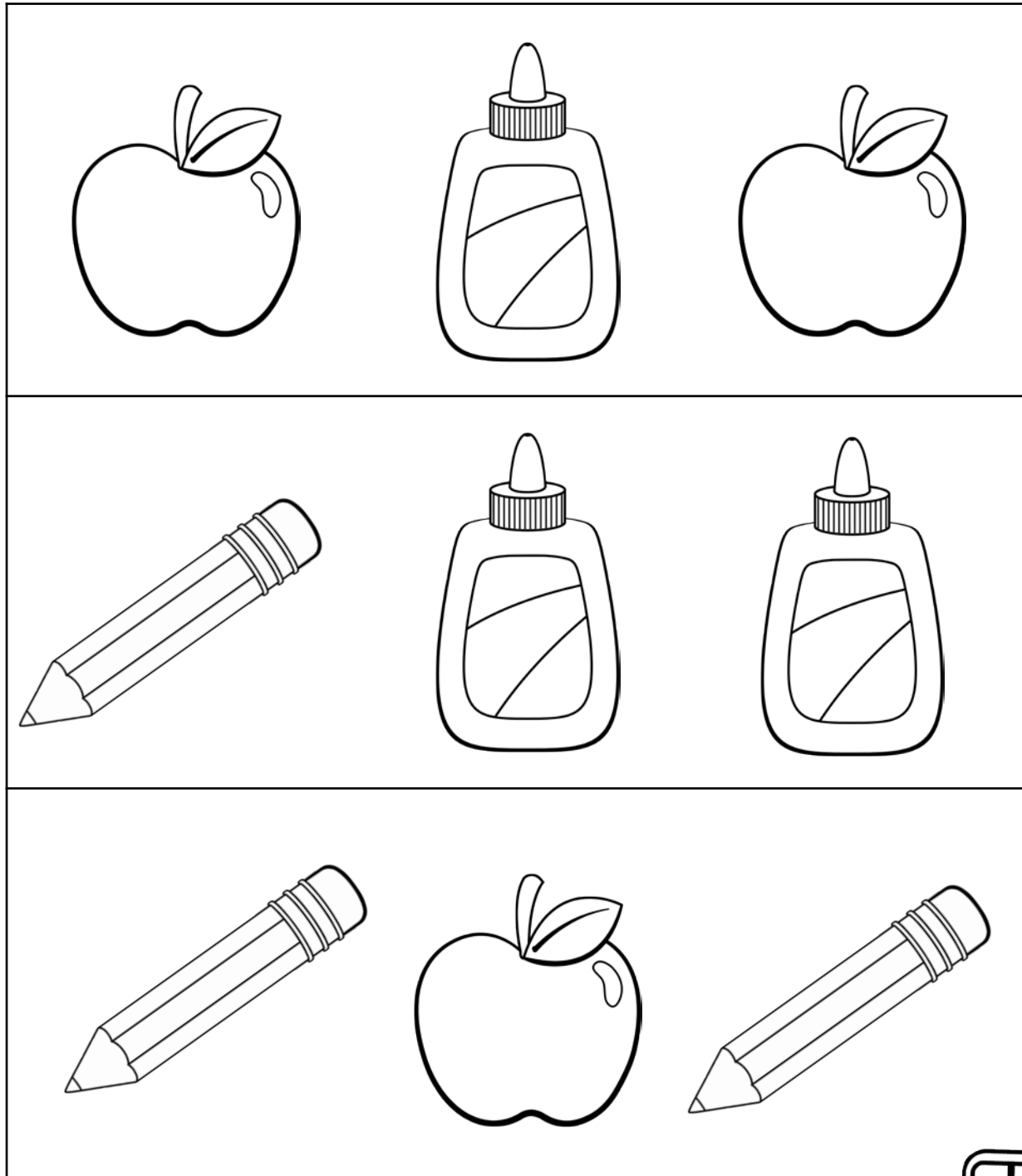

Name: _____

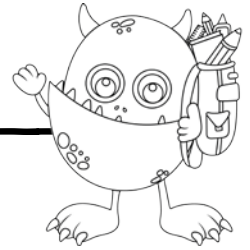

Color the picture that is different.

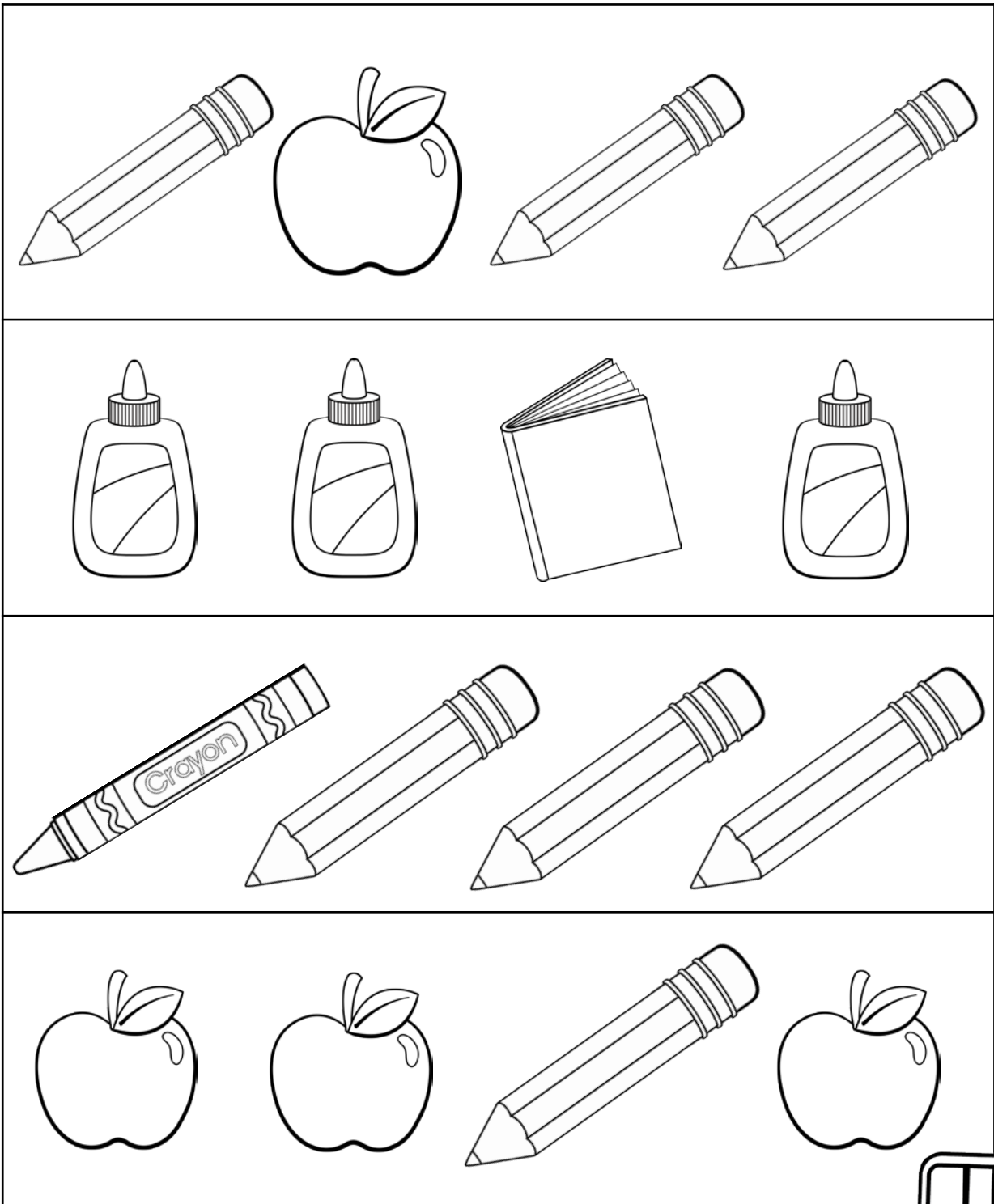

Name: _____

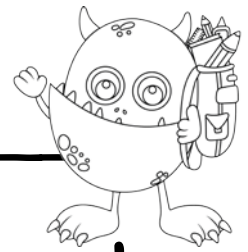



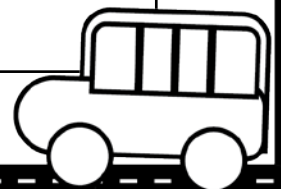
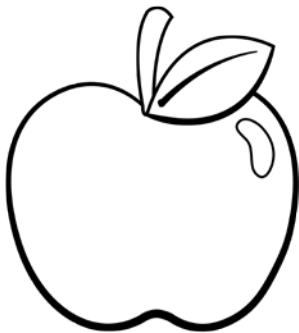
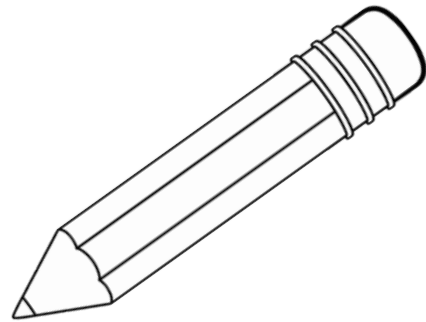
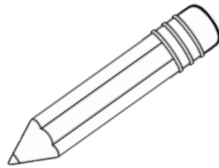
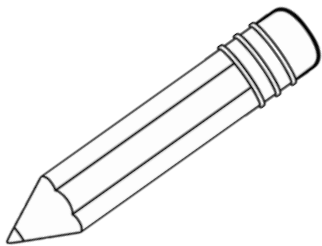

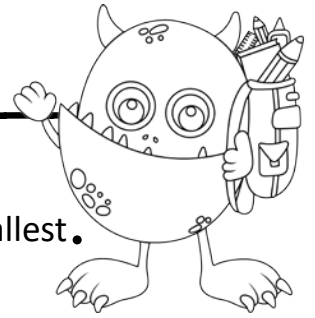

Color the picture that is **biggest**.

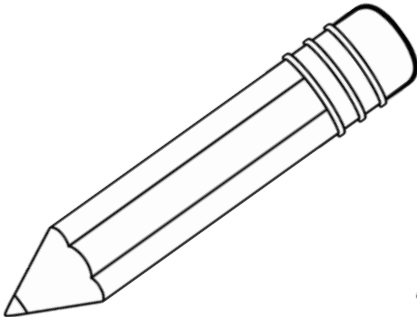
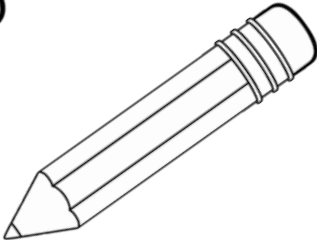
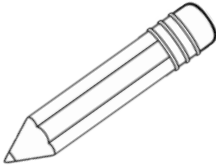

Name: _____

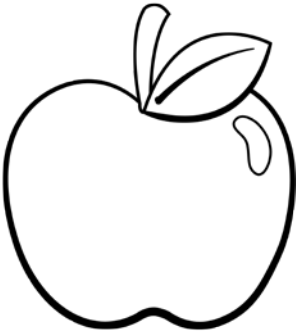

Color the picture that is smallest.

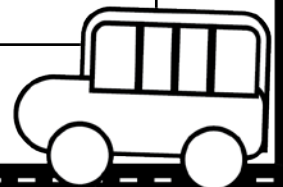

Name: _____

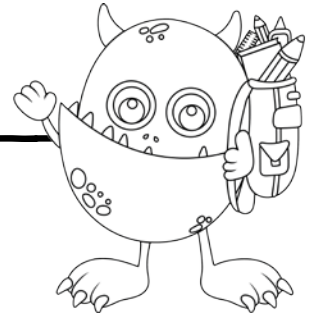

3

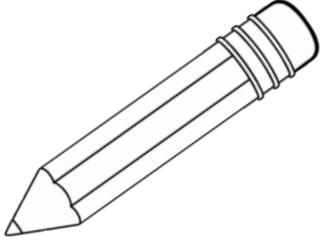
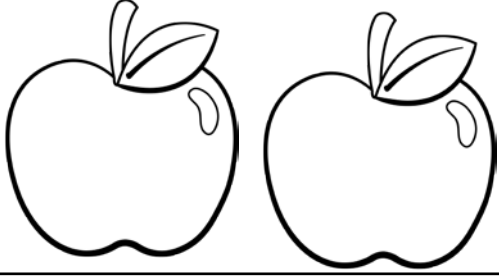
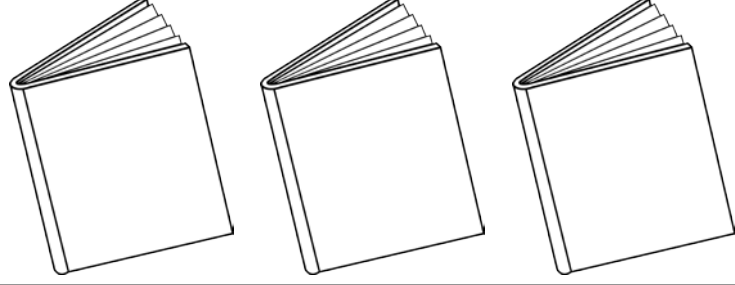
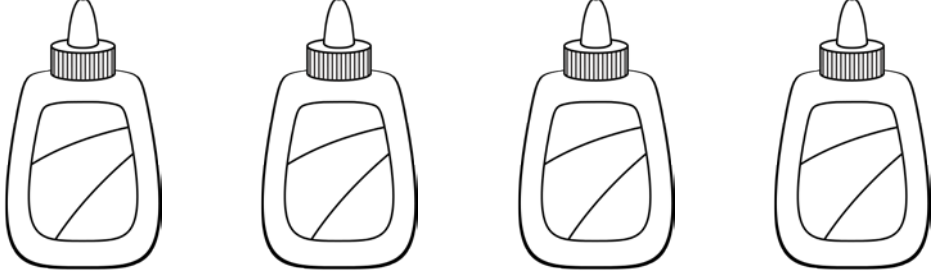
1

4

2

Name: _____

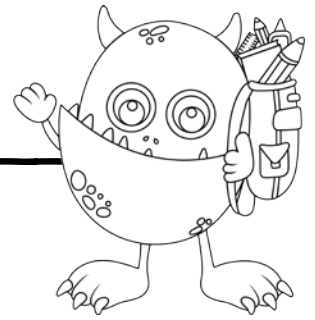

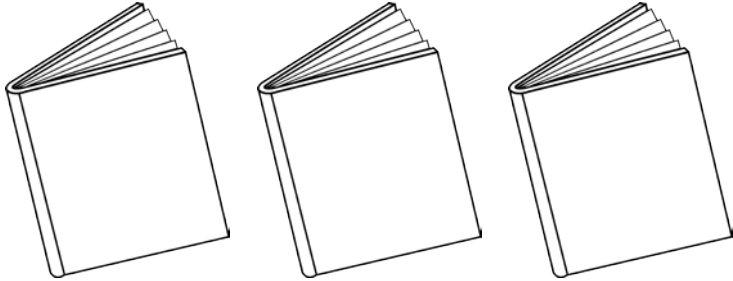
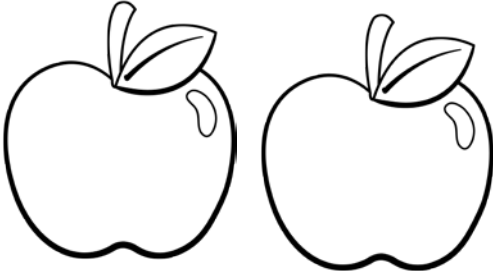
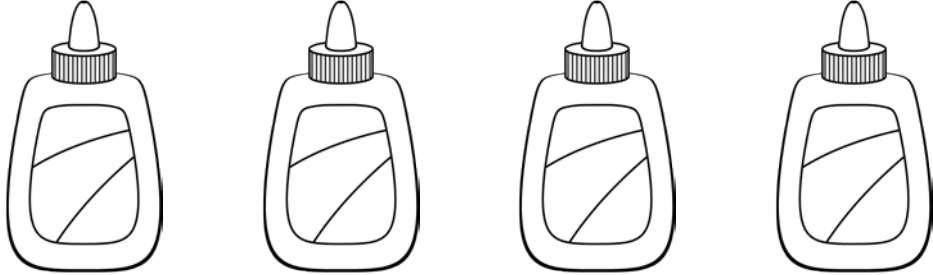
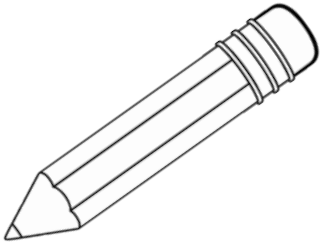
3



1

4

2

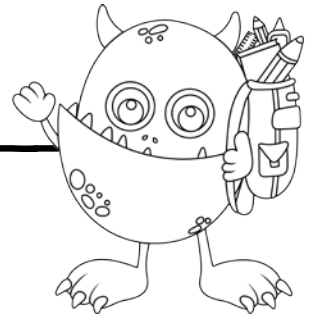
Name: _____

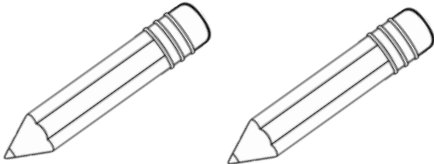
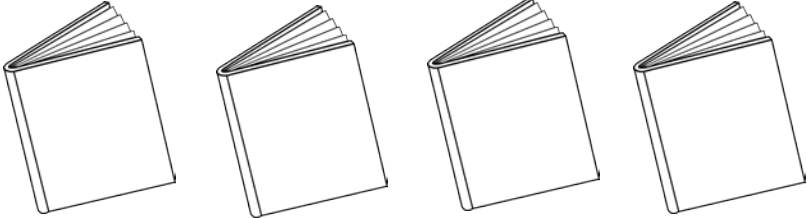
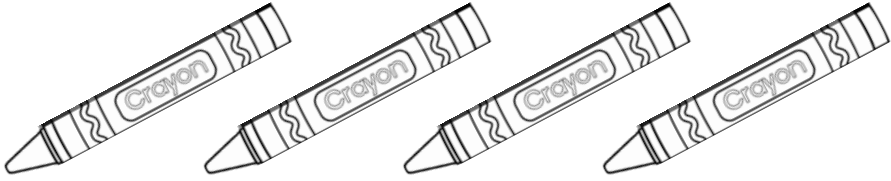

3

1





5

2

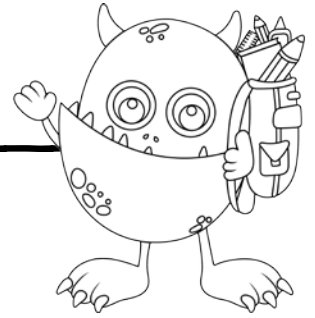
4

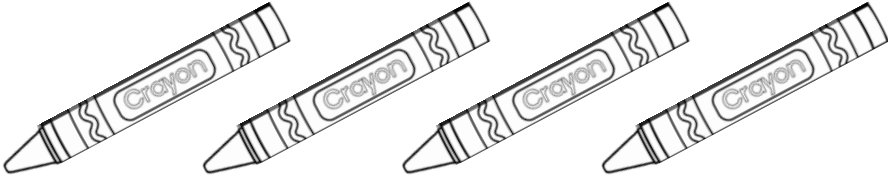
Name: _____

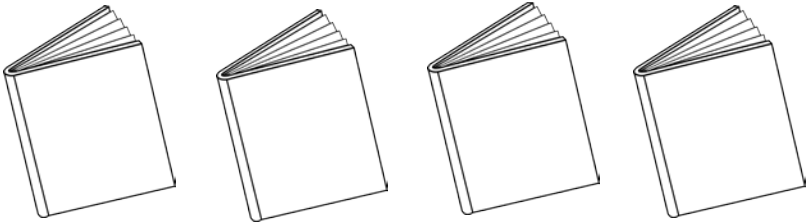

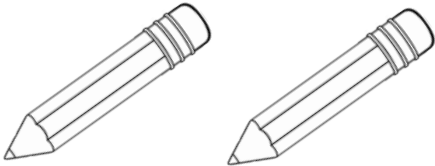
3

1

5

2

4

Name: _____

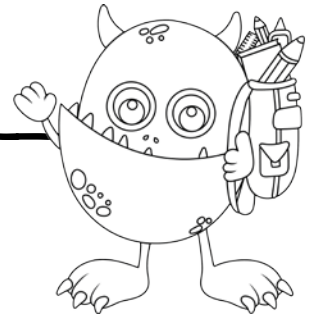

Finish the Pattern

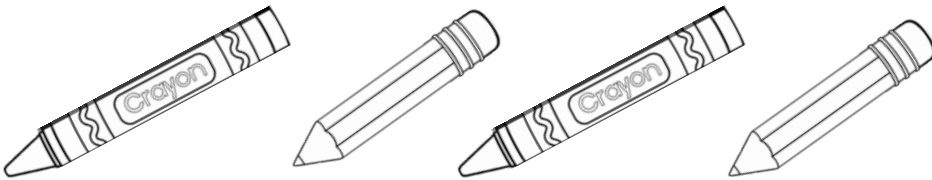
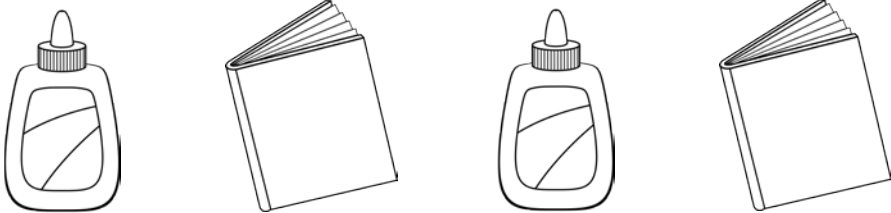
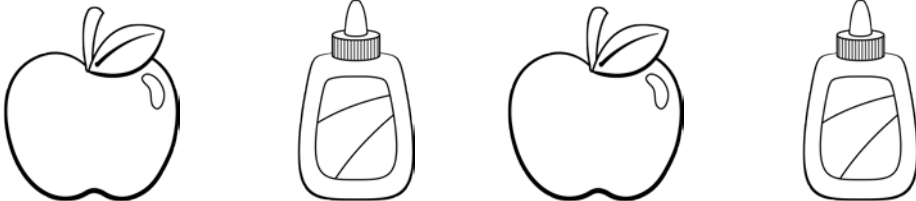
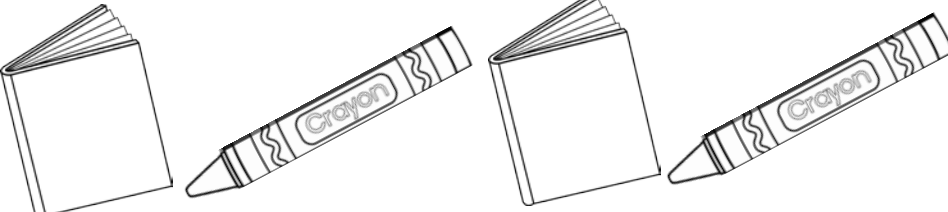

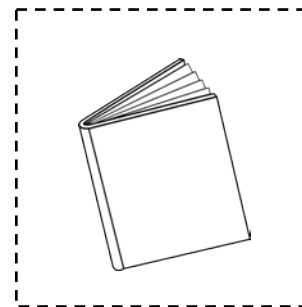
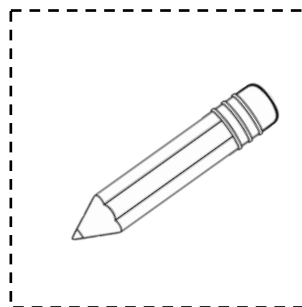
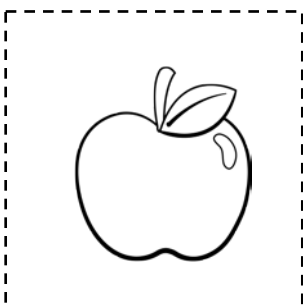

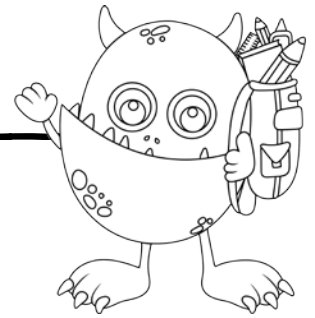

Name: _____

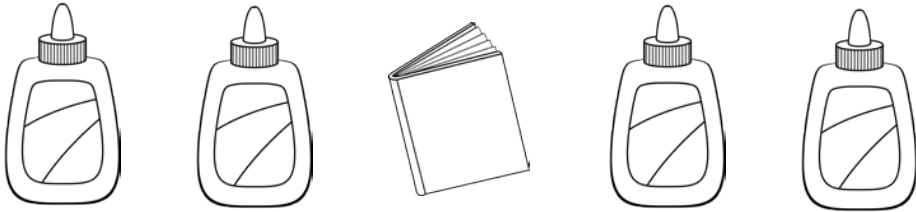
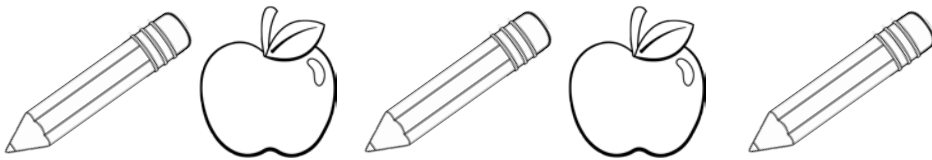

Finish the Pattern

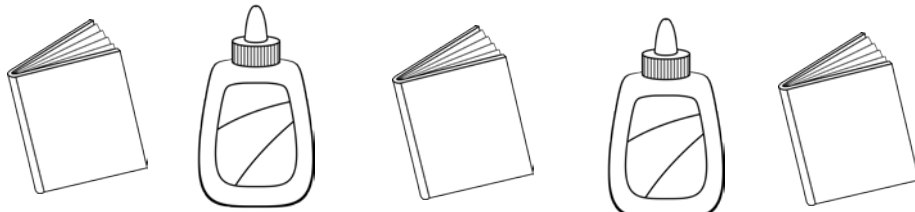

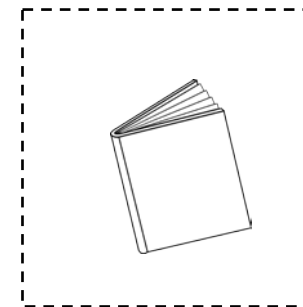
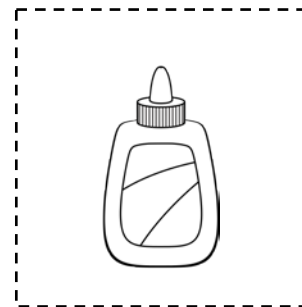
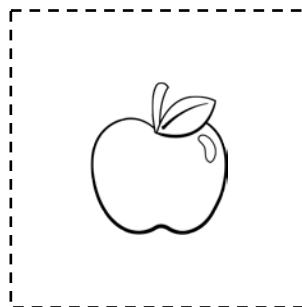
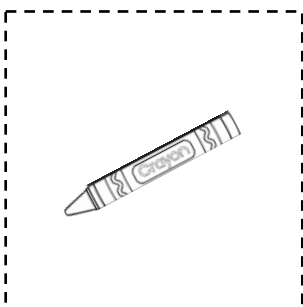

Name: _____

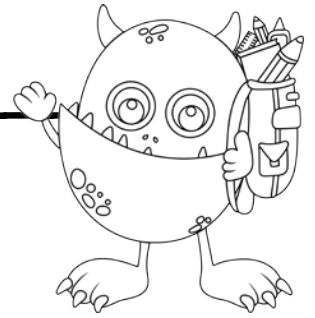

Trace the words.
Color the pictures.

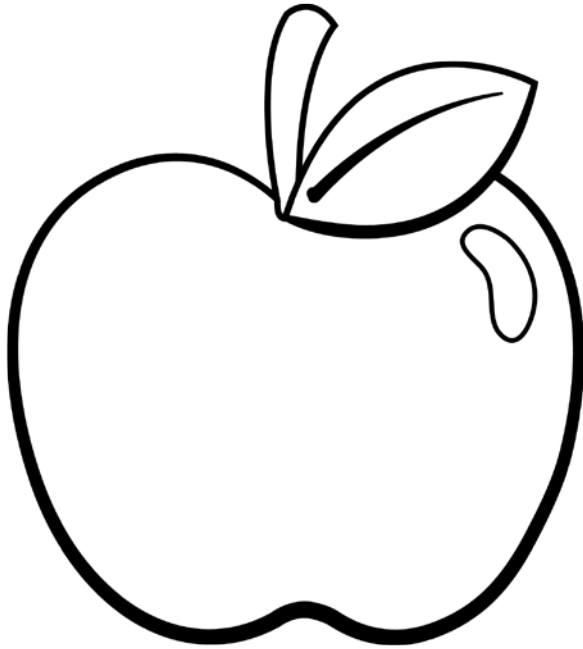

red

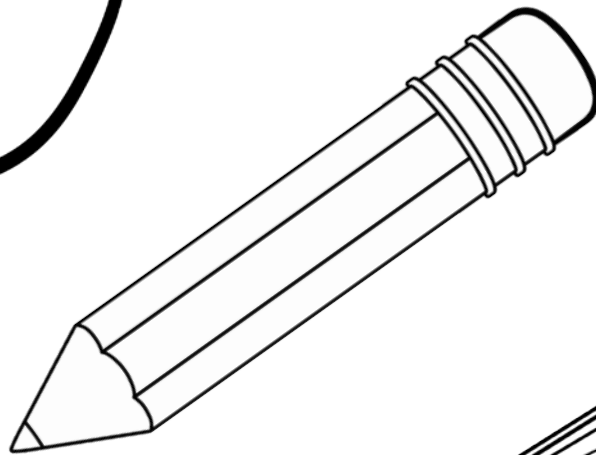

yellow

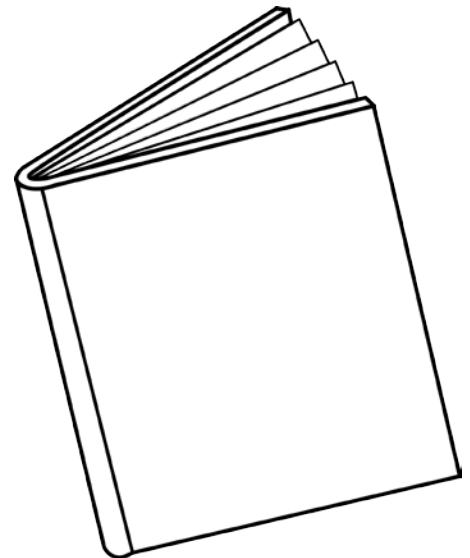

blue



Name: _____

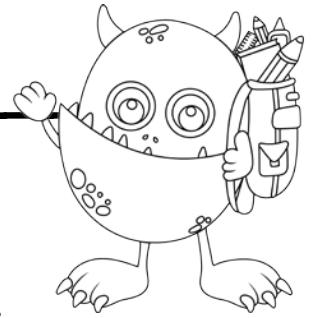

Trace the words.
Color the pictures.



orange

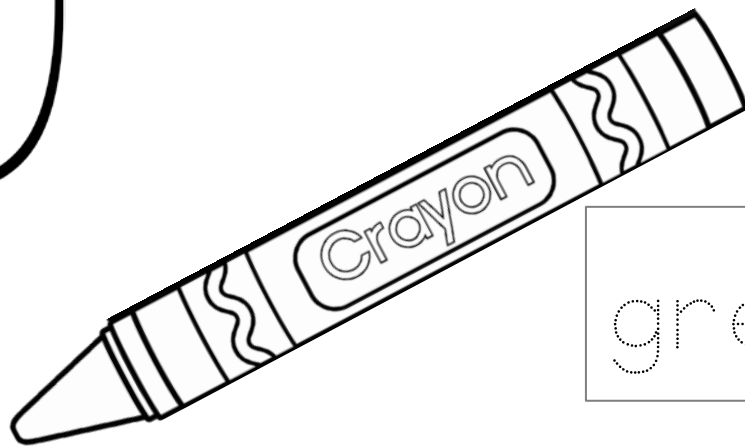

green

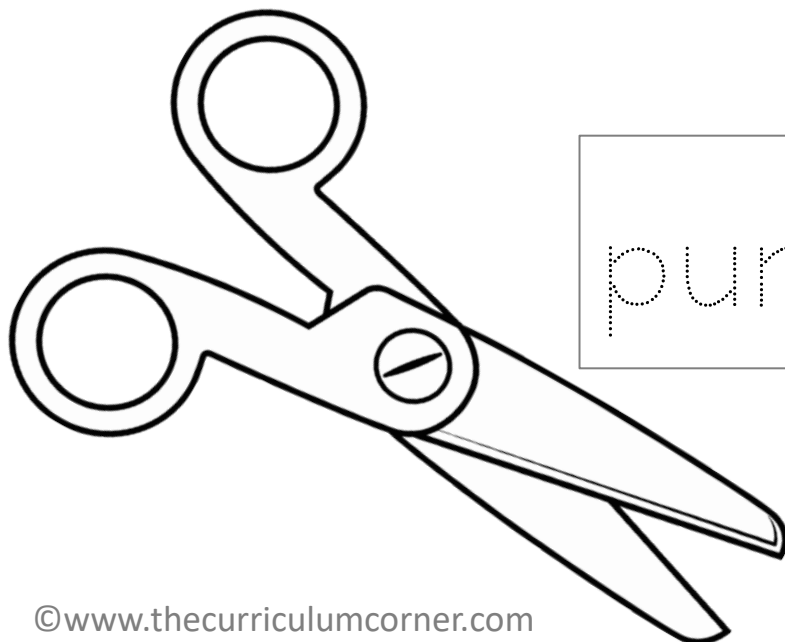

purple



Name: _____

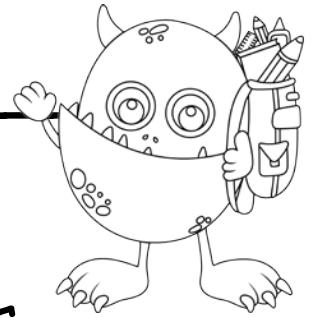

Counting

Count and color the pictures.

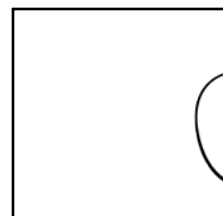
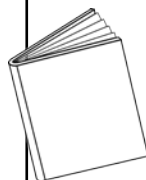
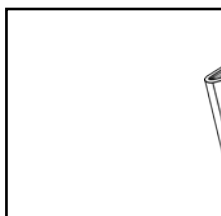
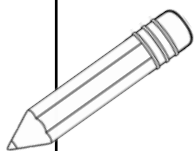
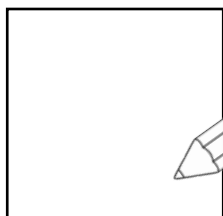
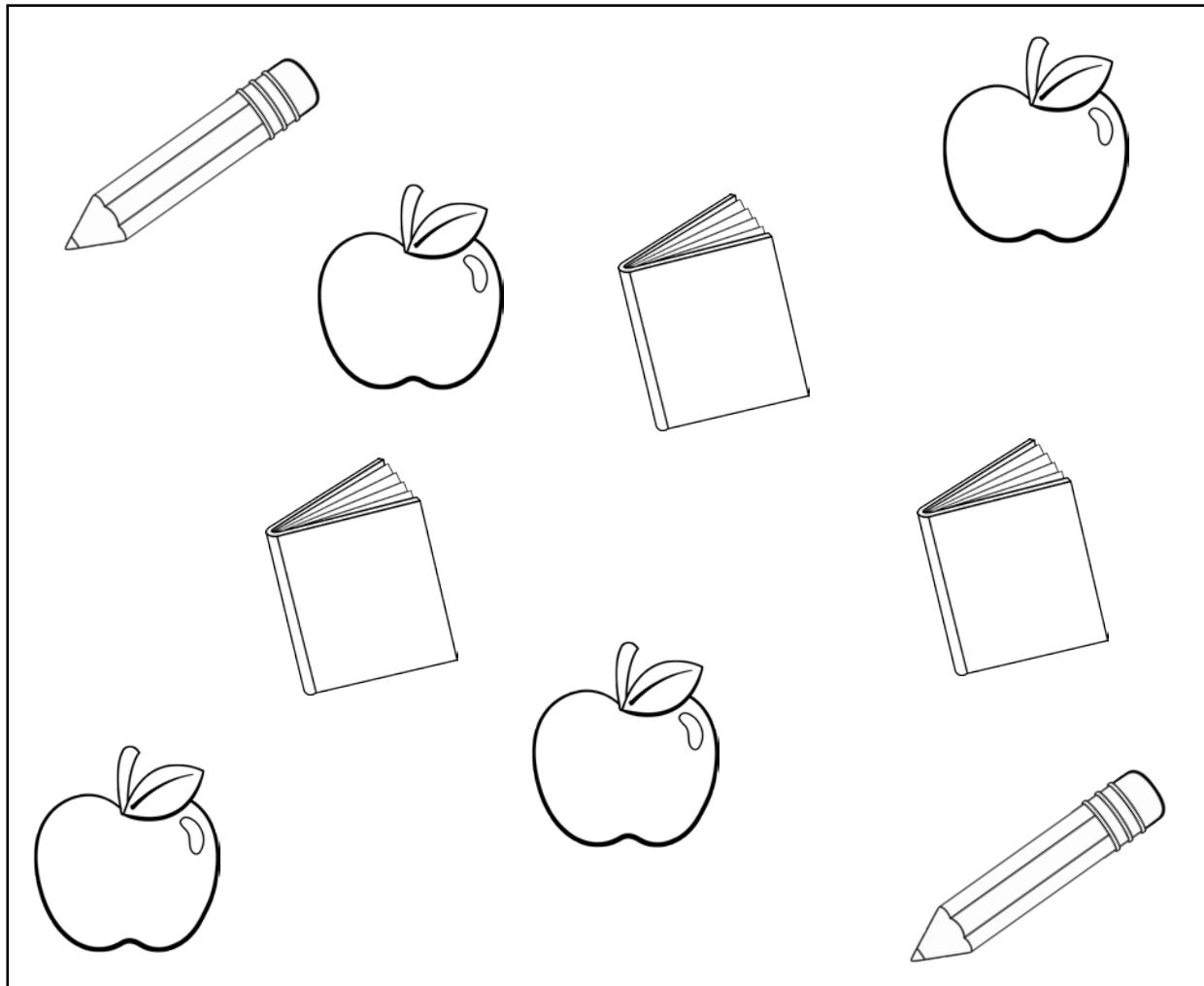

Name: _____

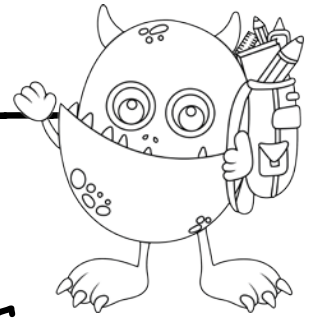

Counting

Count and color the pictures.

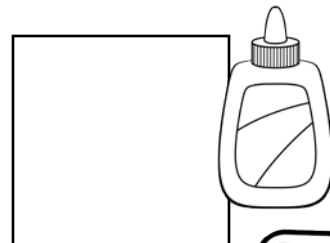
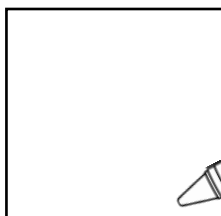
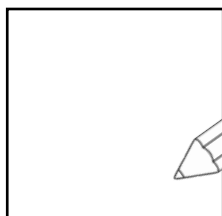
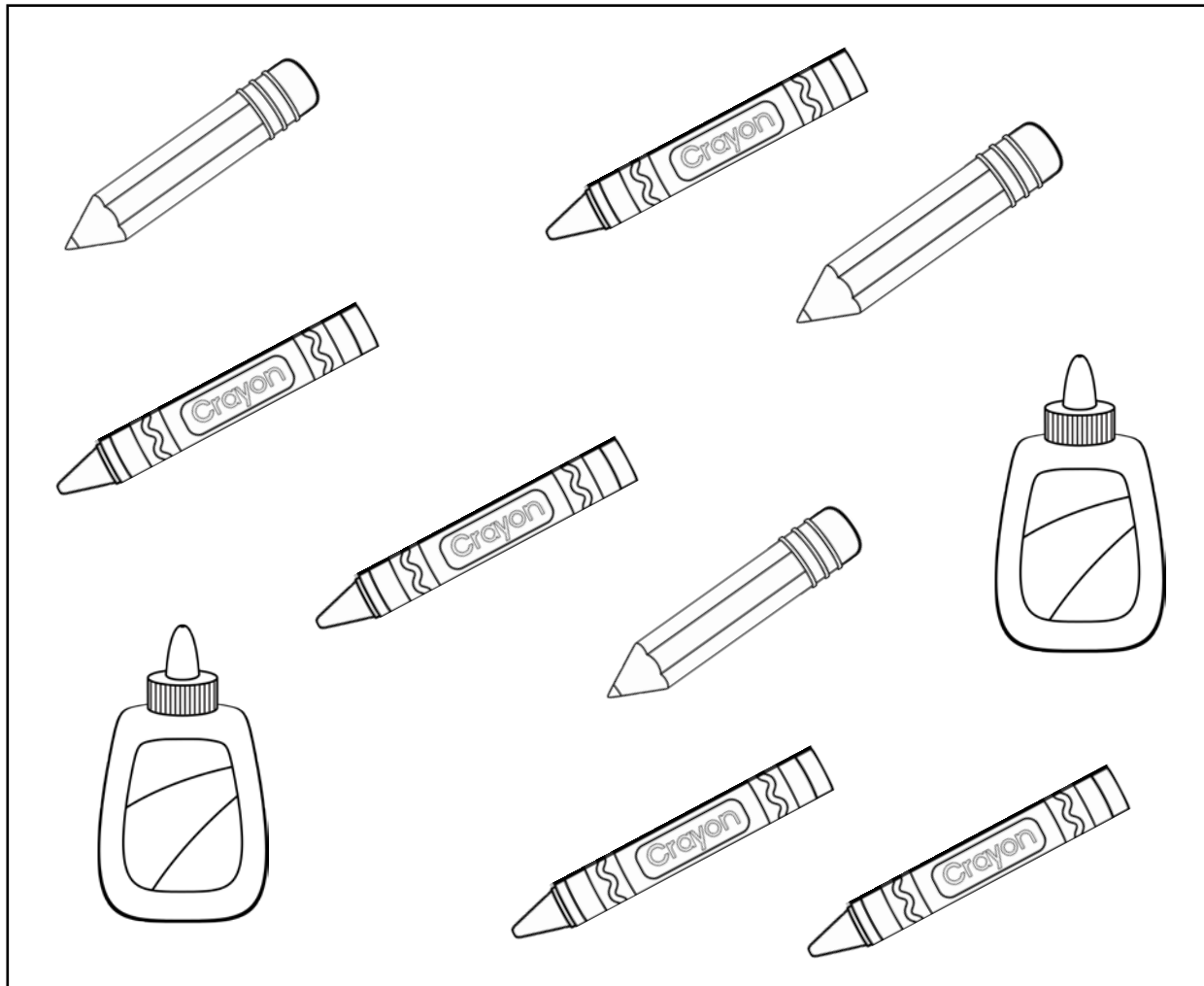

Name: _____

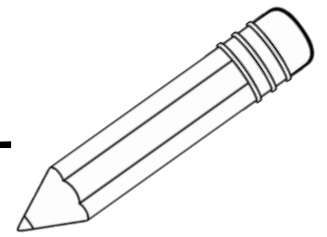

letters	numbers

2	A	1	4	C
E	D	5	B	3

Name: _____

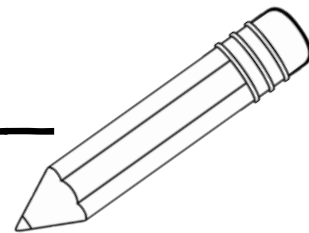

letters	numbers

2	a	1	4	c
e	d	5	b	3

Name: _____

BIG or little?

BIG	little

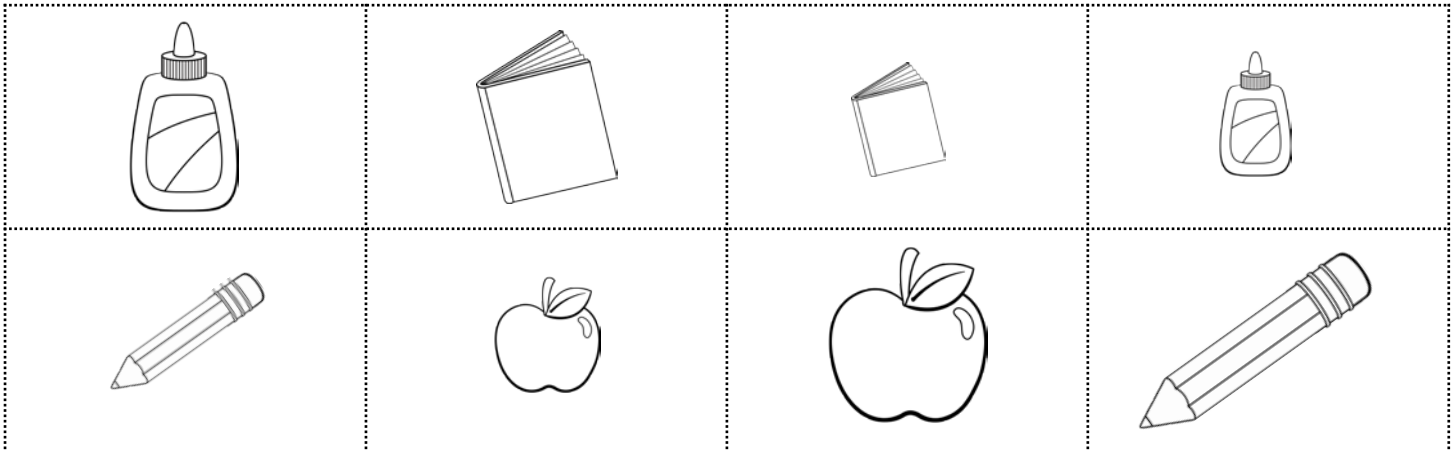

Name: _____

Match the Pictures

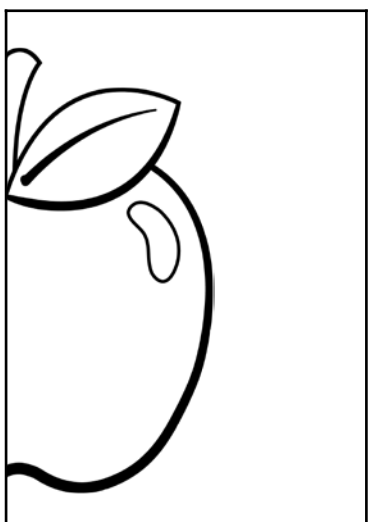
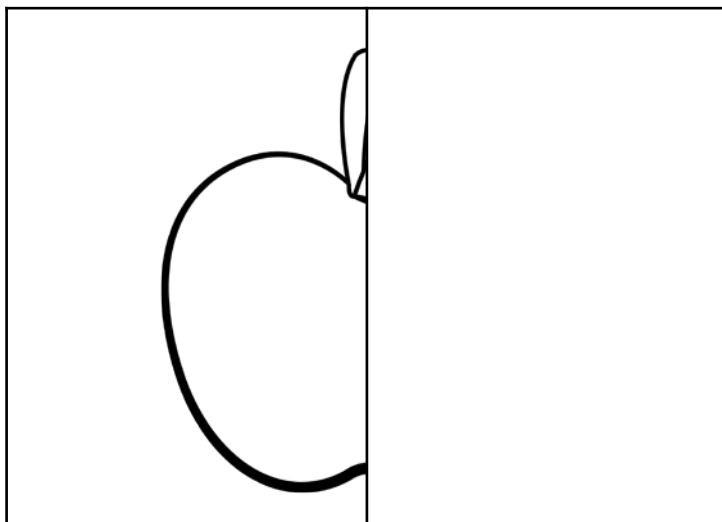
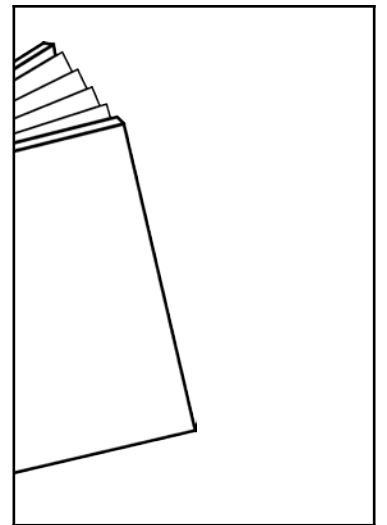
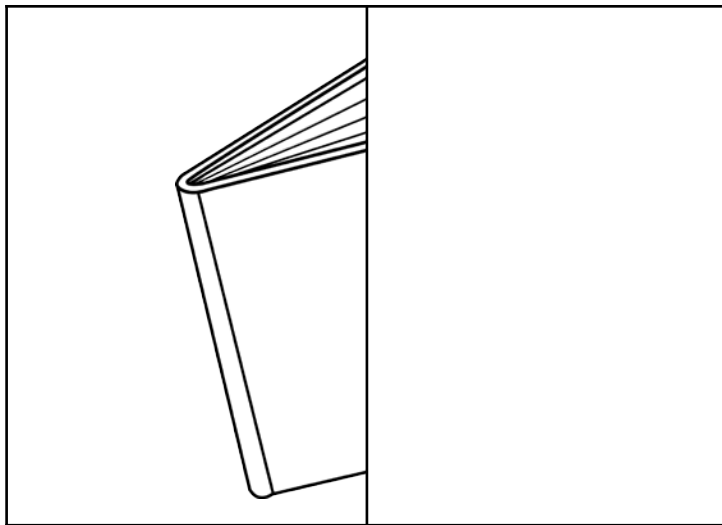
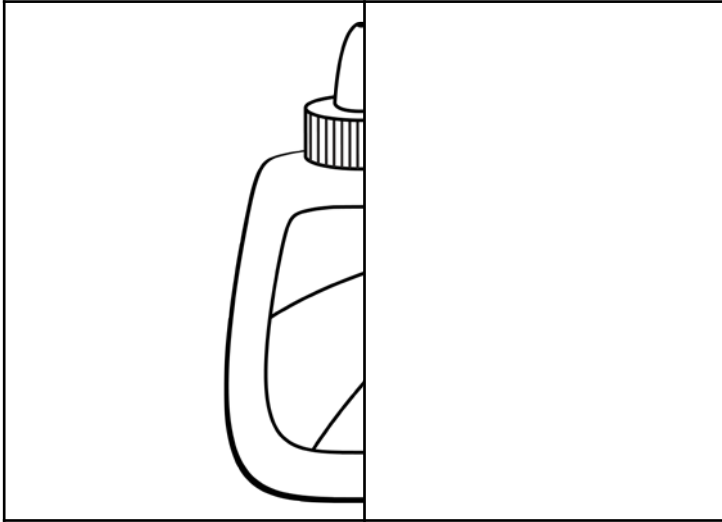

Name: _____

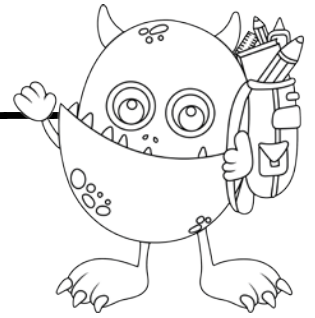

Draw what you see at school.



MY SCHOOL STORY

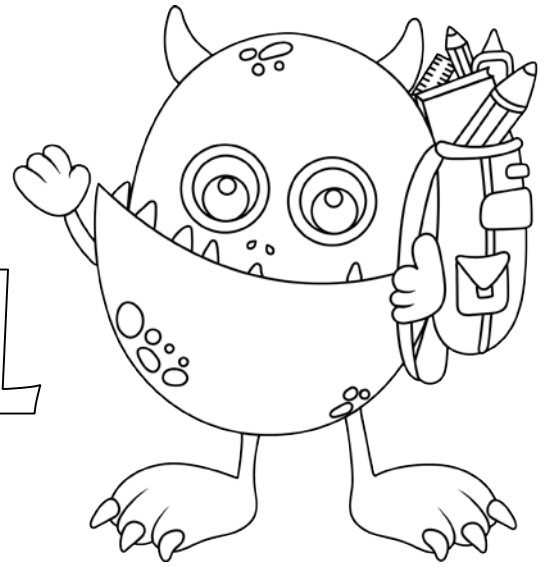

Name: _____



Name: _____

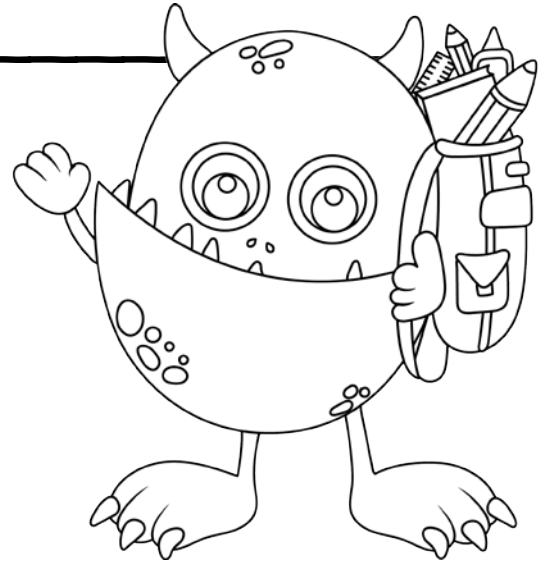

Name: _____

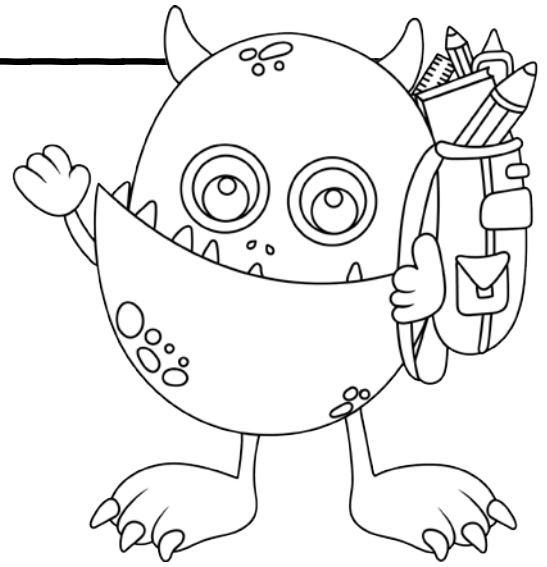



Name: _____

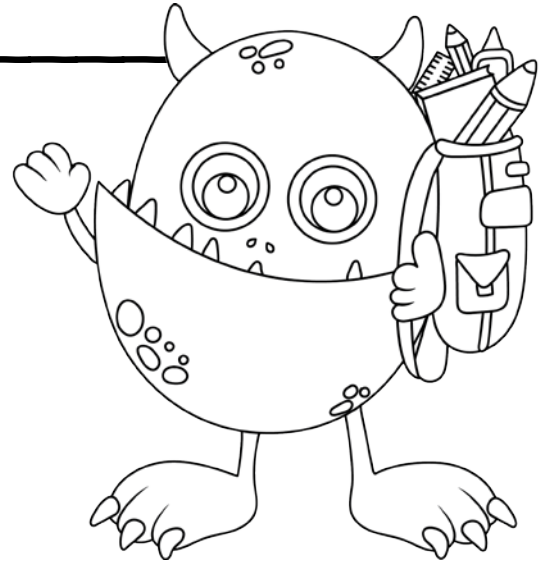



Name: _____

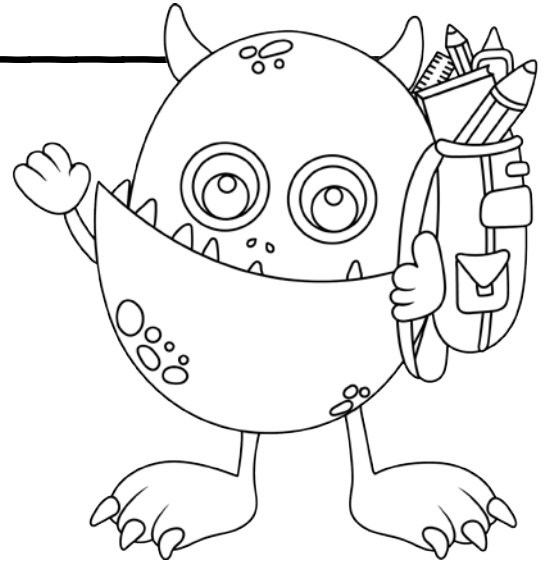

Name: _____

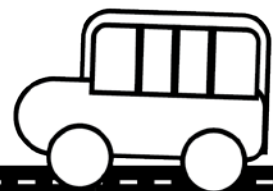

Name: _____

